

Contents

Preface to the Second and Third Edition	v
Preface to the First Edition	vii
1 Safety & Recycling	1
1.1 Hazards	1
1.2 Recycling	2
2 Quick Start	3
2.1 Step 1: Connect Batteries	3
2.2 Step 2: Turn On	5
2.3 Step 3: Log In	5
3 Input Devices	7
3.1 Keyboard	8
3.2 OLED Menu	9
3.3 Trackball	11
3.4 Trackpad	12
4 Linux Console Basics	13
4.1 Console and Shell	13
4.2 Root User	14
4.3 Create a New User and Password	14
4.4 Logging In and Out	15
4.5 Sudo	15
4.6 File System	16
4.6.1 Filesystem Hierarchy	17
4.6.2 Home Directory	18
4.6.3 Dot Files	18

4.6.4	Permissions	19
4.6.5	Pipes	20
4.6.6	Links	20
4.6.7	Finding Files	21
4.6.8	Mount Points	21
4.7	Environment Variables	22
4.8	Working with Text Files	23
4.9	Scripts	24
4.10	What Is My Computer Doing?	24
4.11	Inspect Hardware	25
4.12	Clock	26
4.13	Network	26
4.14	Bluetooth	27
4.15	Dual Display	27
4.16	Shutdown	28
4.17	Standby	29
4.18	Installing and Removing Software	29
5	Graphical Desktops	31
5.1	Sway and GNOME	31
5.2	The Sway Desktop	32
5.2.1	Tiling	33
5.2.2	Launching Applications	33
5.2.3	Top Bar	34
5.2.4	Workspaces	34
5.2.5	Display Brightness	35
5.2.6	Sway Config File	35
5.2.7	Network, Wi-Fi, and Bluetooth	35
5.2.8	Sound	36
5.2.9	Keyboard Layout	36
5.2.10	Trackball/Trackpad Speed	37
5.2.11	External Displays	37
5.3	The GNOME Desktop	38
5.3.1	Launching Applications	39
5.3.2	Top Bar	39
5.3.3	System Menu: Volume, Brightness, Network	40
5.3.4	Sound	41
5.3.5	Settings: Keyboard Layout, Displays and More	41
5.4	Alternative Desktops	42

6	Software	43
6.1	Preinstalled Software	43
6.2	Updating Software	46
6.3	Flashing the System Image	47
6.4	Reform Tools	48
6.5	Running x86 Software	49
6.6	GPU Hacks	49
7	Hardware	51
7.1	Case Parts	52
7.1.1	Main Box	53
7.1.2	Keyboard Frame	54
7.1.3	Screen Back	55
7.1.4	Screen Front	57
7.1.5	Bottom Plate	58
7.1.6	Port Covers	59
7.2	Motherboard	60
7.2.1	Revised Versions	61
7.2.2	System Controller	63
7.2.3	Flashing the Firmware	65
7.2.4	Expansion Port	67
7.2.5	mPCIe Socket	68
7.2.6	M.2 Socket (Key M)	69
7.3	Processor Module	70
7.3.1	Display Connector	71
7.4	Heatsink	71
7.5	Keyboard	72
7.5.1	Keyboard Firmware	73
7.5.2	Backlight	74
7.5.3	Replacing a Keycap	74
7.5.4	Replacing a Keyswitch	75
7.6	OLED Module	75
7.7	Trackball	77
7.7.1	Trackball Cleaning	78
7.7.2	Trackball Firmware	79
7.8	Trackpad	79
7.8.1	Trackpad Firmware	80
7.9	Exchanging Trackball and Trackpad	81
7.10	Battery Packs	81

7.10.1	Compatible Battery Cells	83
7.11	Compatible Displays	83
8	Advanced Topics	85
8.1	Troubleshooting	85
8.1.1	Boot Issues	85
8.1.2	Serial Console	87
8.1.3	Electronics Repair	88
8.1.4	System Controller	89
8.1.5	Software Issues	89
8.2	System Boot	89
9	Schematics	91
9.1	Motherboard Schematics	91
9.2	Motherboard Bill of Materials	104
9.3	Keyboard Schematics	111
9.4	Keyboard Bill of Materials	115
9.5	OLED Schematics	116
9.6	Trackball Schematics	118
9.7	Trackball Bill of Materials	120
9.8	Trackball Sensor Schematics	120
9.9	Trackball Sensor Bill of Materials	122
9.10	Trackpad Schematics	122
9.11	Trackpad Bill of Materials	124
9.12	Battery Pack Schematics	124
9.13	Battery Pack Bill of Materials	126
9.14	Assembly Parts	126
10	Online Resources	129
11	Credits	131

Preface to the Second and Third Edition

Another edition of the MNT Reform Operator Handbook—so soon? Well, we are astonished, too! The past five years went by so quickly and a lot has changed since we first introduced our MNT Reform laptop, so it's about time to provide a fresh, up-to-date handbook.

Since the initial release of Reform, we have developed several Processor Modules, updated software, firmware and hardware, and made changes based on open source contributions from the MNT community. We have created quite a few Reform products by now, such as the Reform Standalone Keyboard, the Pocket Reform and the Reform Next. They are all compatible with each other, forming the MNT Reform Series.

At the time of writing, more than 1500 people call MNT Reform Series devices their own—amazing! Your support means a lot to us and keeps us going.

With MNT Reform, we provide open and sustainable alternatives to today's closed hardware ecosystems. Our devices are meant to be understood and improved by anyone—and community is a vital element in this context. By helping each other and working together we have a chance to create a future where accessible open hardware thrives.

Many of you participate in the MNT Community¹, actively sharing the progress of your customizations, additions of new features or modifications to your Reform(s). Feel free to drop by—we'd like to see you there!

¹<https://community.mnt.re>

Preface to the First Edition

Early in the MNT Reform project, we made—working in the kitchen—13 prototypes for us and a handful of adventurous people. These were much more primitive predecessors of the laptop that you received today, based on an older processor and an eclectic mix of materials. Each already came with an *Operator Handbook*: 30 manually bound pages of schematics and instructions for handling the prototype. It was but a rough sketch of the book that you are reading now.

The original handbook turned out to be an icebreaker and conversation aid when talking about MNT Reform with other people. We wrote this new handbook in the same spirit: to make your MNT Reform more approachable, understandable, but also more discussable. The book will be your companion when taking MNT Reform apart and learning the basics of using the machine.

At a time when electronics are becoming ever more secretive, MNT Reform and this book buck the trends—but they are not sacred artifacts. They are meant to be taken apart, discussed, hacked, built upon. Scribble in the margins. Make it your own.

Chapter 1

Safety & Recycling

1.1 Hazards

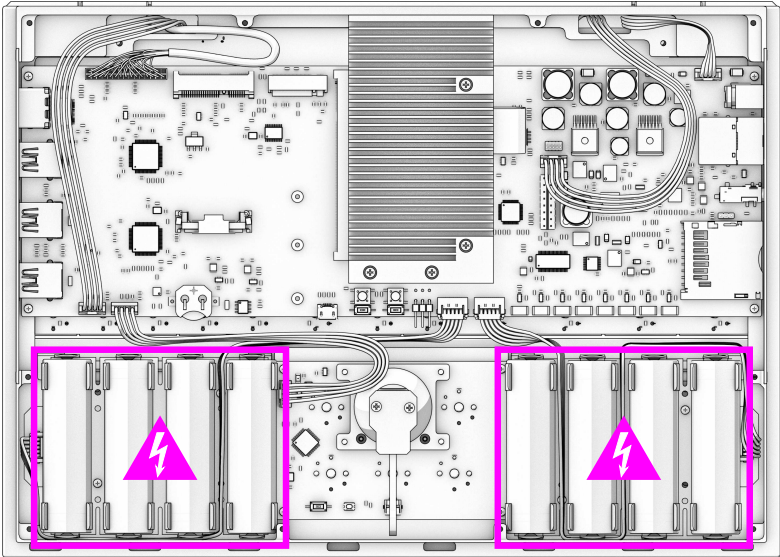

Before you get started with your MNT Reform, please read these safety instructions carefully to prevent harm to yourself and your environment.

Electrical Shock and Fire Hazard: Please be extra careful while and after opening the case of the device. MNT Reform uses 8 batteries in series. When fully charged, these combine to a voltage of almost 29 volts, and the battery cells can easily deliver multiple amperes of current. Do not touch the metal pins of the battery holders with metal tools.

Before servicing anything on the inside, make sure that the wall power is unplugged and remove all battery cells.

Damage to Hearing: The headphone output of MNT Reform can be forced to extreme volume which may damage your hearing if you are not careful. Please make sure to set the volume to 30% or less before connecting headphones to MNT Reform, and then adjust the volume to a comfortable level.

1.2 Recycling



Don't throw any MNT Reform parts in the trash! Batteries and electronics contain materials that are harmful to the environment if not properly disposed of.

You can mail any of the parts back to MNT Research, and we will recycle them for you. Alternatively, you can recycle batteries at a local battery collection facility and dispose of electronics and cables at a local e-waste facility.

Chapter 2

Quick Start

2.1 Step 1: Connect Batteries

To prevent discharge during shipment, the battery cables are not connected by default. After reading about **Safety** in the previous chapter, unscrew the 10 bottom screws and remove the bottom plate. Attach the two battery cable plugs to the battery connectors on the motherboard, then reinstall the bottom lid.

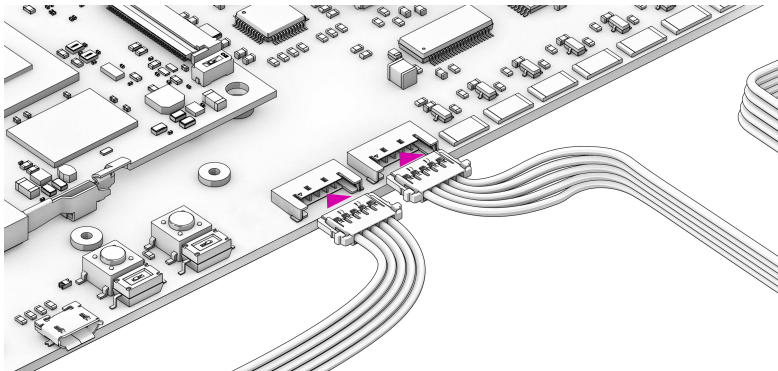

- Bottom Case Screw ×10

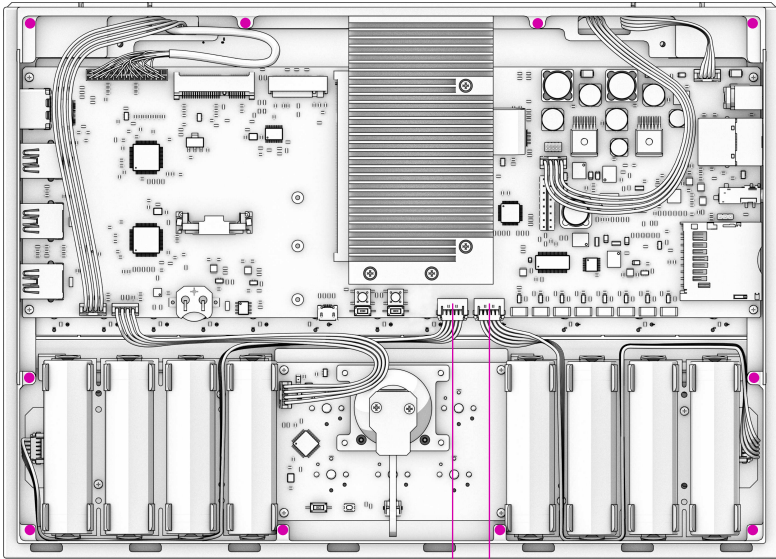

Battery Connector 1

Battery Connector 2

2.2 Step 2: Turn On

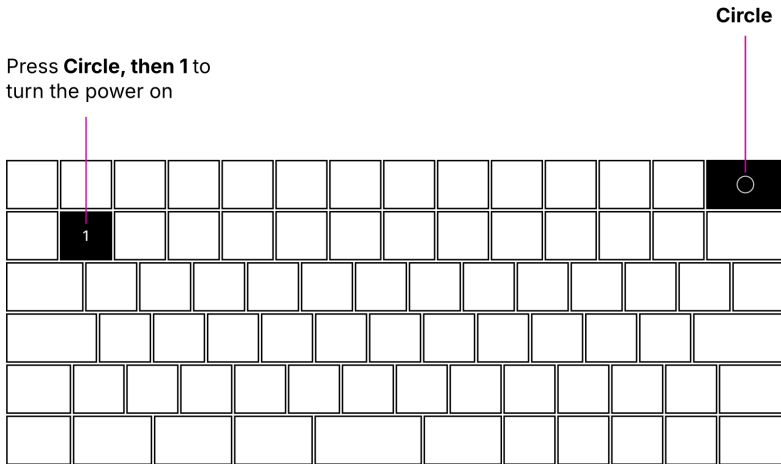

To turn Reform on, press *Circle* and then *1*.

The *Circle* key is used for system control commands. When you press *Circle*, a menu of system control functions and their shortcuts will be displayed on the OLED screen embedded in the keyboard.

To save power, the status of the *Circle* key will only be queried once per second, so you need to press *Circle* for at least one second for the menu to show up.

2.3 Step 3: Log In

After being powered on, the main processor will boot the operating system installed on eMMC flash memory. The operating system's kernel will show diagnostic information as it activates all the devices in the system until finally arriving at the login prompt. On first boot, the Setup Wizard will walk you through the configuration process. You'll select your keyboard layout and your time zone, choose a desktop environment, and finally, create a user account. Once

everything is set up, you can start installing software and using MNT Reform. If you are new to the Debian GNU/Linux operating system or want to learn about specifics of the system software shipped with MNT Reform, please refer to the chapters "Linux Console Basics", "Graphical Desktops", and "Software".

The following chapter will introduce you to the input devices of MNT Reform.

Chapter 3

Input Devices

MNT Reform comes with a keyboard and either a trackball or a trackpad preinstalled. All of the input devices are modular and can be swapped in and out. They all connect via internal USB 2.0 cables.

3.1 Keyboard

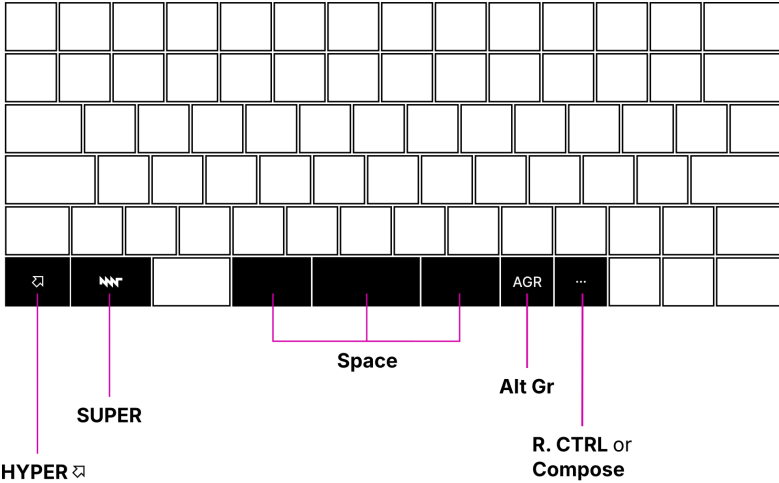

With our newest keyboard¹, we designed in all necessary concave keycap sizes to achieve a traditional stagger, and a contiguous convex space bar which is easier on the thumbs. It is still split, but you can hit it without even thinking about it. If you're an advanced user, you can also remap two of these space keys. Additionally, we included two homing keycaps to improve navigation while touch typing.

Because many advanced users remap the traditional Caps Lock key to a different function, we swapped Caps Lock for a *CTRL* key. This makes the use of *CTRL* key combinations more ergonomic.

Next to the new *AGR* key—short for “Alternate Graphic”, located next to the space bar—is a key with 3 dots (an

¹If you happen to own one of the first MNT Reform laptops, you might have noticed a slightly unusual layout of the keyboard. Back in the day, we simplified the traditional typewriter-based layout so that the keyboard could be constructed using only two distinct key shapes that were available to us (square and 1.5x). The biggest difference was the split space bar: instead of one long key, there were two 1.5x wide space keys, with left and right Alt keys sandwiched between them. However, this proved to be too experimental a layout for some people to get used to.

ellipsis). It is intended as a user-defined key, which is mapped to *Right CTRL* by default. We recommend remapping this key to *Compose*, a key that allows you to generate Unicode symbols from Compose sequences.

Lastly, MNT Reform features an additional modifier key, the *HYPHER* key, in the lower left. *HYPHER* provides an additional layer of key combinations. Here is the list of shortcuts you can use with *HYPHER*:

Shortcut	Function
<i>HYPHER+F1</i>	Decrease Brightness
<i>HYPHER+F2</i>	Increase Brightness
<i>HYPHER+F7</i>	Previous Track
<i>HYPHER+F8</i>	Play
<i>HYPHER+F9</i>	Next Track
<i>HYPHER+F10</i>	Silent
<i>HYPHER+F11</i>	Volume Down
<i>HYPHER+F12</i>	Volume Up
<i>HYPHER+←</i>	Home
<i>HYPHER+→</i>	End
<i>HYPHER+↑</i>	Page Up
<i>HYPHER+↓</i>	Page Down

3.2 OLED Menu

Selected Function	Shortcut Key
Exit Menu	ESC
Power On	1
Power Off	0
Reset	r

The keyboard has a built-in OLED display for interaction

with the System Controller on the motherboard. You can highlight an option and scroll through the menu by using the \uparrow and \downarrow keys. To trigger the highlighted option, press *ENTER*. Alternatively, you can press the shortcut key that is displayed on the right hand side of each menu option. For example, to show the Battery Status, press *B* when the menu is active. To leave the menu, press *ESC*.

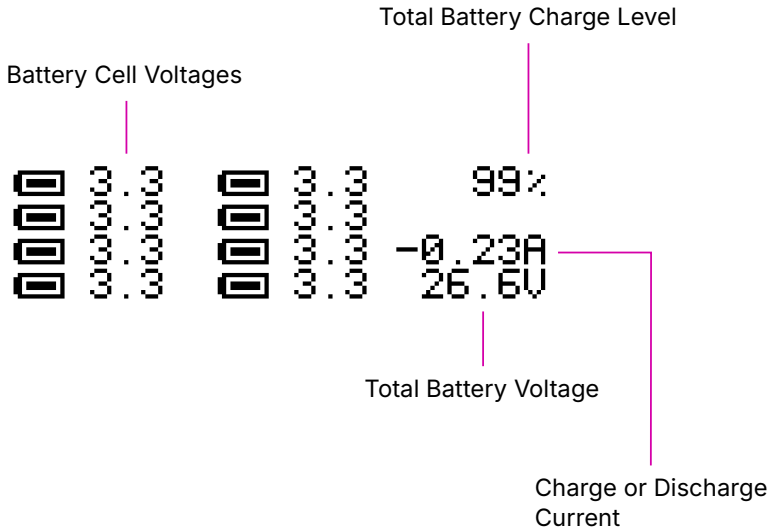

You can see detailed battery information including the estimated total charge percentage on the Battery Status screen reachable through the OLED menu. Each cell icon corresponds to one of the eight battery cells. The leftmost group of four icons represents the battery pack on the left side of the device, and the group on the right represents the battery pack on the right—assuming you look at MNT Reform when flipped on its back and the batteries closest to you.

For the left pack, the top battery icon represents the leftmost cell in the pack, and the bottom icon represents the rightmost cell. For the right pack, it is the other way around, because the pack is rotated by 180 degrees in the laptop.

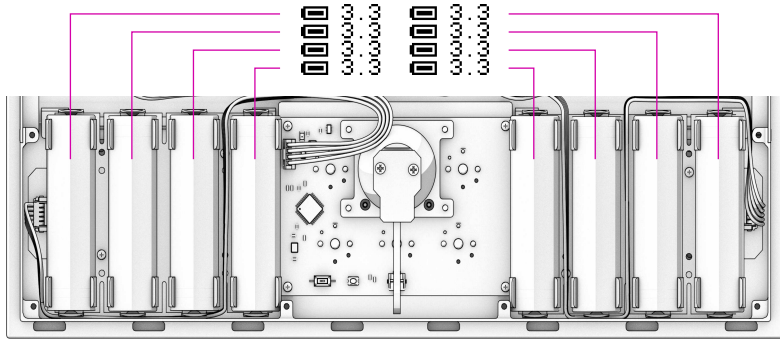

The illustration shows which icon and voltage on the OLED display corresponds to which battery cell in the device.²

3.3 Trackball

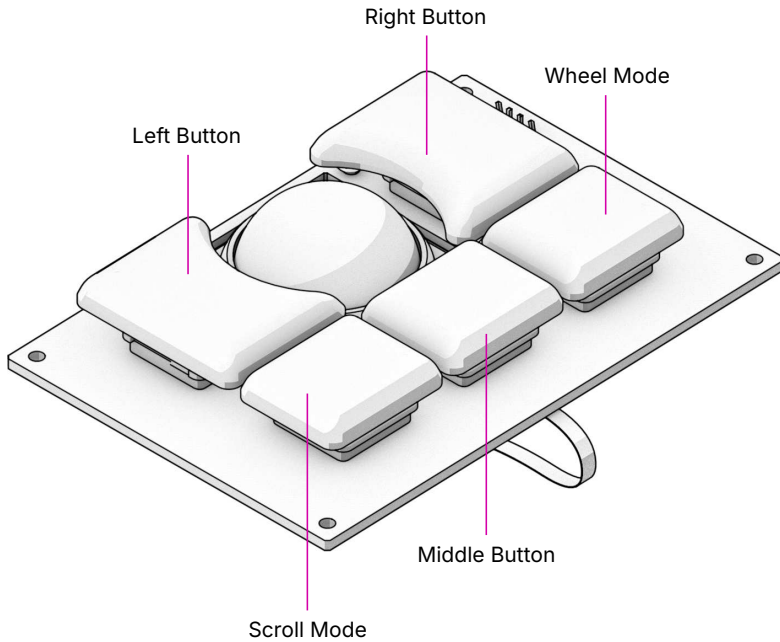

²Note that this order is only valid for the Protected Battery Boards.

The trackball works like a mouse with three buttons (left, middle, and right click). Roll the ball to move the cursor. In addition to the standard mouse buttons, the trackball also has two *Scroll Mode* buttons. Holding down either while moving the ball will scroll the currently focused content. Pressing both *Scroll Mode* buttons together will turn on *Sticky Scroll Mode*, so that you can scroll through a longer text without needing to hold down a button.

3.4 Trackpad

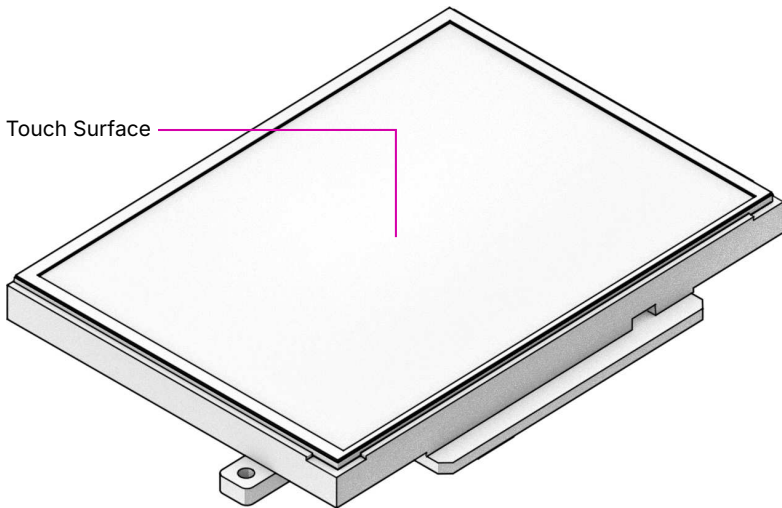

Unlike the trackball, the trackpad doesn't have any buttons. Slide one finger across the surface to move the cursor. Tapping with one finger acts like a left mouse button click. Slide two fingers across the surface to scroll in any direction. Tapping with two fingers performs a right click. To click and drag, use three fingers. Tapping with three fingers is equivalent to a middle click.

Chapter 4

Linux Console Basics

4.1 Console and Shell

MNT Reform ships with a lightly customized Debian GNU/Linux distribution. Once powered on, MNT Reform will boot to a login screen.

From here, you can reach a graphical desktop or the Linux console. If something goes wrong, you can always go back to the console and fix things—if you know a few basics of Linux administration. To reach the console from the login screen, you can use the key combination *ALT+F1*, or *ALT+F2* to go to the second console, etc.

After logging in on the console, you are in control of a shell. The default shell is called `bash`¹, but there are many other shells available. You can use the shell to type in commands for your computer to execute, but also to write programs (scripts) that combine commands to do more complex tasks. For example, this handbook is generated by a `bash` script combining a few text and graphics related tools.

This chapter will introduce you to the basics of exploring and

¹The “GNU Bourne-Again Shell”.

administering your MNT Reform system using the shell first and then a graphical desktop. You can also launch shells on the desktop to use tools that don't have a graphical user interface. Using these tools, you can troubleshoot some problems with the operating system by yourself.

4.2 Root User

The most powerful user in the system is `root`. When logged in as `root`, you can modify but also destroy any file in the system. To prevent others from logging in as `root`, you should protect the account with a password (the Setup Wizard asks you to do this). In the shell, you execute all commands by typing them in and pressing *ENTER*. To set your password, execute this command:

```
passwd
```

The `passwd` command will ask you for a new password two times, but will not display it while typing (so it cannot be gleaned by onlookers).

During normal Linux usage you will rarely want to be `root`—only when performing changes to the system configuration, which includes adding or removing users or software and controlling background services. Instead, you should create a less privileged user account for yourself.

4.3 Create a New User and Password

You have created a user in the Setup Wizard after powering on your MNT Reform for the first time. In order to add another user account to the system, log in as `root` and execute the `adduser` command:

```
adduser kim
```

This will create a new user named `kim`, and add a new home directory for `kim` at `/home/kim`. The `adduser` command will ask

you for a password and a few questions that you can skip by just pressing *ENTER*.

If you want to change the password for the user `kim` later, you can use the `passwd` command as before:

```
passwd kim
```

4.4 Logging In and Out

You can log out of the console or a terminal window by pressing *CTRL+D*. Alternatively, you can type `exit` in the terminal.

When logged out, you will see the login prompt. Type the username that you added in the previous step and press *ENTER*. Next, type your password (it is not displayed). Press *ENTER* to complete the login.

4.5 Sudo

To make bigger changes to the system you will often need to use a command that requires `root` (superuser) privileges. Logging out of your user account just to log back in as `root` is inconvenient. Instead, you can temporarily become `root` by either switching to it as `su` (switch user) or give your regular user account `sudo` privileges².

`Sudo` allows you to use a command as `root` by typing `sudo command`—but only if you are a member of the `sudo` group. To add your user to the `sudo` group, first log out and login as `root`. Then you can execute the following command:

```
usermod -a -G sudo kim
```

(Substitute your username for `kim` here).

²`sudo` means “switch user and do”.

The `-a` flag means “Append the user to the group”, while the `-G` option specifies the name of the group you want to add the user to: `sudo`.

Log out and login as your regular user again. From now on, you can execute commands which require root privileges using `sudo`. For example, to shut down your computer safely before turning it off, you can type:

```
sudo shutdown now
```

4.6 File System

Your system’s file storage is organized in a tree of directories. To move around in it, you use the `cd` command to change the current directory. The top of the hierarchy is called root (not to be confused with the superuser of the same name), but written as the symbol `/`. To go to the root directory, enter:

```
cd /
```

To see what’s here, use the `ls` (list) command:

```
ls
```

If you want to know more details, such as the modification times and permissions of files, use:

```
ls -l
```

You can also add the flag `-h` to get “human readable” file sizes instead of the raw number of bytes:

```
ls -lh
```

There are two virtual files in every directory, called `..` (two dots) and `.` (one dot). The single `.` means “here” (i.e. the current directory), and you can use it if you ever want to specify the current directory explicitly. For example, if you want to copy the file `/tmp/myfile` to the current directory, you can type:

```
cp /tmp/myfile .
```

To go to the parent directory (a top-level directory that contains subdirectories, the so-called “children”), use:

```
cd ..
```

Commands like `ls` have many options. To learn about them, you can read the built-in manual pages:

```
man ls
```

With `man` you can learn more about any command. You should make yourself familiar with the most important commands like `cp` (copy), `mv` (move), `rm` (remove), `mkdir` (make directory), `mount` and `ln` (link). Armed with this knowledge, you will be able to navigate any UNIX-like system, not only Linux.

4.6.1 Filesystem Hierarchy

When you issue `ls` at the root of the filesystem (`/`), you will see the following directories:

Directory	Purpose
<code>/</code>	Top (“root”) of the filesystem
<code>/bin</code>	Commands (“binaries”), such as <code>ls</code> , <code>cp</code>
<code>/sbin</code>	Commands usually only used by <code>root</code>
<code>/lib</code>	Libraries (common code shared between binaries)
<code>/usr</code>	Files managed only by the package manager
<code>/boot</code>	Boot loader related files (like Linux kernel ³)
<code>/etc</code>	System configuration files
<code>/home</code>	Home directories of user accounts
<code>/root</code>	Special home directory for <code>root</code>
<code>/mnt</code>	A place to mount other filesystems
<code>/media</code>	Another place to mount filesystems
<code>/proc</code>	Live information about processes
<code>/sys</code>	More live information from the kernel
<code>/dev</code>	Device files providing access to hardware
<code>/run</code>	Temporary files related to background services
<code>/tmp</code>	Temporary files—deleted on restarts

³The kernel is the privileged core of the operating system.

Directory	Purpose
<code>/srv</code>	Files used by servers such as web servers

A good way to explore files and directories that take up disk space is using the `ncdu` program. It calculates the size of each (sub)directory and allows you to browse your filesystem and even delete unwanted files (you should only do this in your home directory, though):

```
ncdu /
```

4.6.2 Home Directory

If your username is `kim`, your home directory is located at `/home/kim`. There's a shortcut for your home directory using the tilde symbol `~`. To go to your home directory, you can type:

```
cd ~
```

If you list the contents of your home directory, you will see a number of directories with self-explanatory names, such as `Pictures`, `Music`, `Documents` and `Downloads`. The last one is used by web browsers to store downloaded files, for example. Feel free to create your own subdirectories in your home directory as needed.

4.6.3 Dot Files

Your home directory also contains a number of hidden files and directories called "dot files". Their names start with a dot (`.`) and for tidiness, are usually hidden. To see them, use the `-a` flag with `ls`:

```
ls -a
```

Often times, dot files contain your personal configuration for certain programs. Many programs collect configuration files in the `~/.config` subdirectory.

4.6.4 Permissions

As you are the owner of your home directory, your user account is allowed to modify any files and subdirectories contained in it. But you cannot change system configuration files in `/etc` or delete a command in `/bin`, except if you're `root`. This is because of the ownership and permission settings on these files and directories.

If you list the contents of your home directory with `ls -l`, you will see your username twice in each row, after a cryptic-looking column of letters and dashes and a number:

```
drwxr-xr-x  4 kim kim 4096 Nov  2 20:52 Music
rw-r--r--   1 kim kim   8 Jan  9 20:03 notes.txt
```

The letters and dashes at the beginning describe the file mode bits of the file or directory. A "d" at the beginning signifies a directory. The following 9 letters are three triplets describing "user" (owner), "group", and "all" permissions, in that order. "r" means read, "w" write and "x" execute. An "x" on a file means that this is an "executable", a program that can be run, or in the case of a directory, that it can be entered.

The first occurrence of a username in each row is the owner of the file or directory. The first triplet of mode bits on `notes.txt` tells you that you, the owner, can read and write but not execute this file (after all, it is just a text file).

The second occurrence of `kim` names the group `kim`, not the user. When you create a new user, the system also creates a group with the same name and only you as a member. You could add other users to your group to share files with them, for example. The second triplet of mode bits, `r--`, tells you that members of this group can only read your file, not change it.

Lastly, the third mode triplet (`r--` in this example) says that any other user logged into your system can read this file.

To change the mode bits of a file, you can use `chmod`. For example, to give nobody but yourself (assuming you're the

owner) the permission to read and write the file `notes.txt`, execute:

```
chmod a=,u=rw notes.txt
```

This invocation first sets an empty list of modes for all users (`a=`) and then read and write modes for the user/owner (`u=rw`) on the file.

To learn more about managing modes and ownership, be sure to read the `man` pages for `chmod`, `chown`, and `chgrp`.

4.6.5 Pipes

Linux features some advanced concepts that are central to the UNIX philosophy (Linux is a flavor of UNIX). One that you will often encounter is the pipe, symbolized by `|`. You can use pipes to feed the output of one program to the input of another program. For example, you can use the pager `less` to paginate a long stream of text, such as the output of `dmesg`. This tool prints all diagnostic messages of the operating system kernel, and using `less` lets you view it page-by-page instead of having to scroll back to the beginning:

```
dmesg | less
```

Or page through a long list of files:

```
ls -la ~/Downloads | less
```

You can also build more complex pipelines. The following command will output the last 5 lines containing the word “usb” in the kernel log:

```
dmesg | grep usb | tail -n 5
```

4.6.6 Links

If you list the contents of `/usr/lib` with `ls -l` you will see a number of files that point to another file with an arrow (`->`). This is because the file on the left hand side is a “symbolic link” to the “real” file on the right hand side. Symbolic links

and “hard links” can be created using the `ln` command as a means to point to a file using another name. This can be useful to create shortcuts. Refer to the manual page with `man ln` to learn about the details of links.

4.6.7 Finding Files

If you don’t remember where you put a file, or want to search a complex hierarchy of directories for something specific, you can use `find`:

```
find -name "notes*"
```

This will display any file or subdirectory whose name starts with “notes” in the current directory. `man find` will reveal many more options for finding files.

The `rgrep` command will look for words in the content of a file:

```
rgrep --color spice
```

This will look for any occurrence of the word “spice” in files in the current directory and its subdirectories, and display each line in which the word was found, with the word itself highlighted.

4.6.8 Mount Points

The root directory `/` is actually a collection of filesystems “mounted” into one virtual filesystem. These can be located on different disks, media or even the network—or be purely virtual in the case of `/dev`, `/proc` or `/sys`.

For example, if you want to access files stored on a USB stick, you would first mount one of the filesystems contained on the USB stick into an empty directory called a mount point. This could be something like `/mnt` or `/media/usb-stick`. Usually, desktop environments can help you to automatically mount removable media, but it’s useful to know how to do the same process manually.

First, you need to find the block device of the media you want to mount. For this, you can use the command `lsblk`. An example (partial) `lsblk` output could be:

NAME	MAJ:MIN	RM	SIZE	RO	TYPE	MOUNTPOINT
sda	8:0	1	28.9G	0	disk	
sda1	8:1	1	28.9G	0	part	

Here, `sda1` is the block device of the first partition on the USB stick. If you are unsure which is the right device, you can issue `dmesg -w` and then plug in the USB stick. You'll see something like this appear in the kernel log:

```
[...] sd 0:0:0:0: [sda] Attached SCSI removable disk
```

Which tells you that `sda` (or in your case, something else) is the block device you're looking for.

To mount the partition on the USB stick at `/mnt`, do:

```
sudo mount /dev/sda1 /mnt
```

If successful, this will—in UNIX tradition—output nothing, and you can find your files by navigating to `/mnt` with the usual commands.

Before unplugging your USB stick, you should unmount it. This makes sure any pending changes are written to the device (note that the command is `umount`, not “unmount”):

```
sudo umount /mnt
```

4.7 Environment Variables

As the shell is not only a command interpreter but also a programming environment, it supports variables. These are placeholder names that contain a value that can be changed at any time. For example, you could make a universal greeting command like this:

```
echo Hello, $name.
```

The output of this command changes depending on the value of the variable `$name`. To change the variable:

```
name=World
```

If you now execute the same `echo` line as before, you'll see this output:

```
Hello, World.
```

Variables are often used to define an environment for other programs. This means that a program can change its behavior according to these variables. These so called environment variables are set before starting the program. To see all currently defined environment variables, you can use the `env` command. You will see a few specific ones among the output:

```
HOME=/home/kim  
PWD=/home  
SHELL=/bin/bash  
USER=kim
```

This means that another way to reach your home directory is `cd $HOME`, and another way to refer to your username is `$USER`. A critically important variable is `$PATH`, which is a list of directories (separated by `:"`) that the shell searches when looking for a command that you want it to execute. For example, when you type `ls`, your shell will only find it if `/bin` is in your `$PATH`, because `ls` actually resides at `/usr/bin/ls`.

4.8 Working with Text Files

Most system configuration is done by editing text files.

The two most common text editors in Linux are `vim` and `emacs`, which both have a steep (but rewarding) learning curve. Thus, Reform system provides an editor more suited for beginners called `micro`.

You can create, view, and edit files using the `micro` text editor. To edit a file in the current directory named `file.txt`, use:

```
micro file.txt
```

While in `micro`, you can use `CTRL+S` to save, `CTRL+Q` to quit, and `CTRL+G` to display a help menu.

4.9 Scripts

By now you know most of the ingredients to be able to write shell scripts: programs interpreted by the shell. By writing shell scripts, you can create your own commands to extend the capabilities of your computer. Here is an example script that greets the user:

```
#!/bin/bash

day=$(date +%A)
echo Hello, $USER. Today is $day.
```

The first line of the script, called the “shebang” line is important to tell the operating system that this script is to be interpreted by the shell `/bin/sh`. Save the script to a file named `greet.sh`. Mark the file executable and execute it:

```
chmod a+x ./greet.sh
./greet.sh
```

You can learn more about programming the shell by reading its manual page `man sh`. The more advanced `bash` shell is documented in `man bash`.

4.10 What Is My Computer Doing?

You can check your RAM usage, CPU usage, and processes currently running by using `htop`:

```
htop
```

Hit `F1` to display the built-in help screen.

You will see that there are a few processes running that you didn’t start yourself. These are background processes, also

called services, daemons, or units. They are controlled by `systemd`, the so-called “init system”. It is the first program started by the Linux kernel, and it spawns all other programs including services. You can learn more about `systemd` by reading the manual page:

```
man systemd
```

The most important commands to manage `systemd` are `systemctl` and `journalctl`. Their manual pages are worth a look, too. To see the list of known units and their status, you can use:

```
systemctl
```

To inspect a unit in more detail, you can pass its name to `systemctl`. For example:

```
systemctl status ssh
```

Instead of `status`, you can use verbs like `start`, `stop` or `restart` to control units.

The Linux kernel itself outputs a lot of diagnostic information at boot and when hardware changes (e.g. new devices are plugged in). To see the kernel log, you can (as superuser) use:

```
sudo dmesg -H
```

4.11 Inspect Hardware

The following commands are useful to inspect devices connected internally or externally:

Command	Description
<code>lsblk</code>	List block devices (storage).
<code>lsusb</code>	List USB devices.
<code>lspci</code>	List devices connected to PCIe ports.
<code>lscpu</code>	Get information about the processors.
<code>free -h</code>	Get information about system memory.

4.12 Clock

To see the current date and time, you can use the `date` command. The date and time are set by the `ntp` (“Network Time Protocol”) service by synchronizing to time servers on the internet.

The motherboard of MNT Reform has a battery-backed real-time clock chip (PCF8523T, U5). This chip saves the date and time even if your system is shut down or loses power. You can interact (as `root`) with the clock using the `hwclock` tool. Review `man hwclock` for the details.

4.13 Network

MNT Reform has a built-in Gigabit Ethernet (1 GbE) port for networking. Additionally, you can install a Wi-Fi card in the mPCIe slot (depending on your Processor Module), or the module itself comes with a Wi-Fi chip.

Usually, you want to use a convenient management tool like `network-manager` (preinstalled) and the tool `nmtui` to manage your network connections.

To see and change details of your network connections, you can use the `ip` tool:

Command	Meaning
<code>ip addr</code>	Show the status of the network interfaces ⁴ .
<code>ip route</code>	Show the network routing table.

You can trigger an automatic configuration of an interface via DHCP by executing `dhclient eth0`, and you can change the DNS servers by editing the file `/etc/resolv.conf`.

To connect to a remote computer via a secure shell connection, try `ssh` followed by the IP address of the computer you

⁴`eth0` is the built-in Ethernet; `wlp1s0` is a Wi-Fi interface.

want to connect to. If you want to login to MNT Reform over the network, you can enable the secure shell daemon service as follows:

```
sudo systemctl enable sshd
```

You can then login to MNT Reform from another computer on your local network by executing:

```
ssh kim@192.168.1.242
```

Replace the username `kim` with your own username and the IP address `192.168.1.242` with your own IP address. You can find your IP address by looking for the `inet` entries in the output of the `ip addr` command.

Before using SSH functionality, you should generate a public/private key pair by executing `ssh-keygen`.

4.14 Bluetooth

Some Processor Modules, such as the RCM4 with A311D, feature integrated Bluetooth. This technology lets you connect to wireless devices that are close to your MNT Reform (usually a few meters), such as headsets, speakers or mobile phones. If you ever need to troubleshoot Bluetooth, you can try restarting its service using `systemctl restart bluetooth` or interact with `blueman` on the command line using `bluetoothctl`.

4.15 Dual Display

MNT Reform has an HDMI connector that has different functions depending on the installed Processor Module:

Module	Dual Display
i.MX8MQ	Yes
i.MX8MPlus	Yes

Module	Dual Display
LS1028A	No
RCM4 for Raspberry Pi	Yes
RCM4 with A311D	No
RK3588	Yes

To activate dual display with i.MX8MQ, for example, run the following command:

```
reform-display-config --dual
```

Other modules that support dual display will activate this function automatically.

4.16 Shutdown

To turn off MNT Reform, you should shut down the system cleanly by executing:

```
systemctl poweroff
```

or

```
sudo shutdown -h now
```

On the graphical desktop, you can click the `reform-tray` icon and select `shutdown`.

In the Debian system shipped with MNT Reform, the shutdown process will ask the System Controller to turn off the power. The OLED display will then show an animation of a disappearing MNT Research logo. In case you have to turn off the power manually (for example if the system is unresponsive or you are using an alternative OS), press *Circle* and then *0* (zero).

4.17 Standby

The standby function works with only some of our Processor Modules.

LS1028A doesn't support standby, and at the time of writing, it is still in development for A311D. The i.MX8MQ system-on-chip, on the other hand, can enter a low power standby mode. This function is stable for this module, but always save your work to disk regardless. In our tests, the power consumption in standby mode is roughly halved compared to the normal working mode.

To enter standby mode, execute this command:

```
systemctl suspend
```

You can also use the `reform-tray` icon and select standby mode.

To make the system wake up from standby, select the *Wake* item from the keyboard OLED menu.

4.18 Installing and Removing Software

The Debian GNU/Linux distribution has access to a large number of software packages. No matter which desktop you use, these are centrally managed by `apt`, the package manager. Generally, on a Linux system you rarely download executables from the internet and launch them. Instead, you can cleanly install and remove software packages by using the package manager. `apt` also has the ability to search for keywords (or regular expression patterns):

```
apt search browser
```

This will list all packages in the `apt` cache that contain the keyword "browser". To refresh `apt`'s list of packages available in the online Debian *repository* (the library of packages), use the following command:

```
sudo apt update
```

If you have found a package you would like to install:

```
sudo apt install firefox
```

To remove (uninstall) the package from your system:

```
sudo apt remove firefox
```

To explore all of `apt`'s functionality, read the man pages for `apt` and `apt-cache`. If you are more comfortable with a graphical user interface for managing `apt` (and other) packages, you can install and use the `gnome-software` package.

Chapter 5

Graphical Desktops

5.1 Sway and GNOME

MNT Reform ships with two graphical environments called “desktops”. The Debian distribution, which the system on the eMMC is based on, has a number of additional desktops in its package manager (see section “Alternative Desktops” at the end of this chapter).

1. **Sway** emphasizes the concept of “tiling”. This means that normally, windows don’t overlap, but instead the screen space is automatically divided to make space for new windows. This desktop consumes minimal system resources, but relies heavily on keyboard shortcuts, which makes it harder to learn.
2. **GNOME** features classic overlapping windows, a point-and-click driven interface, and a modern look. In GNOME, you can drag windows to the corners or edges of the screen and they will be snapped. They also have minimize, maximize, and close buttons.

You initially choose between Sway and GNOME in the MNT Reform Setup Wizard. This choice will be reflected as the

default on the login screen, but you can change it by clicking the settings icon after selecting your username (without entering your password) on the GDM login screen.

5.2 The Sway Desktop

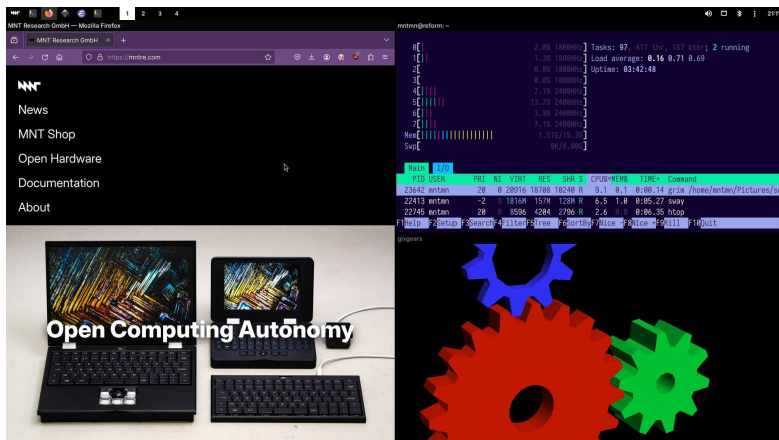

Sway is optimized for use with keyboard shortcuts, most of which are combinations of *SUPER*¹ and other keys. These are the most important shortcuts:

Key Combinations	Function
<i>SUPER</i> +D	Open the launcher to start applications
<i>SUPER</i> +ENTER	Open a terminal
<i>SUPER</i> +ESC	Close active window
<i>SUPER</i> +1...	Go to workspace 1–9
<i>SUPER</i> +SHIFT+1...	Move active window to workspace 1–9
<i>SUPER</i> +SHIFT+S	Take screenshot (in ~/Pictures)
<i>SUPER</i> +SHIFT+X	Take screenshot of an area

¹*SUPER* is the key with the MNT Research logo next to the *HYPER* key.

5.2.1 Tiling

You can start a new terminal window by using the shortcut *SUPER+ENTER*. When you press *SUPER+ENTER* multiple times to open several terminals, you'll notice that your currently open windows will be resized to accommodate for the new window. You can switch between these windows by holding the *SUPER* key and pressing the cursor (arrow) keys in the desired direction.

If you keep adding windows, they will continuously shrink horizontally, but if you would rather have a window split vertically, you can. Use these shortcuts for deciding:

Shortcut	Function
<i>SUPER+H</i>	Split window horizontally
<i>SUPER+V</i>	Split window vertically

Note that the window is not split instantaneously. You're just telling Sway "The next time I create a window, put it below/beside my current window."

You may also use *SUPER+W* to tell Sway to use tabs. You can switch your tab using the same shortcuts for switching between windows. You can end this function by pressing *SUPER+E*. You can use *SUPER+ESC* to close the currently selected window.

5.2.2 Launching Applications

Reform's Sway desktop includes the `wofi` launcher, a popup menu for launching an application by typing a part of its name. Press *SUPER+D* to open the menu. Over time, `wofi` will remember the applications you regularly launch and will sort them by frequency of use.

5.2.3 Top Bar

Sway on Reform comes with an information bar at the top of the screen, which is provided by the `waybar` package. The bar is divided into the following sections:

Section	Action on click
MNT Research logo	Open the launcher
Icons of running applications	Switch to application
Workspace numbers	Switch to workspace
Tray icons	Settings for network, volume, etc.
Clock	Toggle date/clock

You can completely customize the top bar by editing the config file `~/.config/waybar/config` and the CSS-based styling file `~/.config/waybar/style.css`.

`man waybar` explains the available configuration options.

5.2.4 Workspaces

If you have a lot of windows open, they might not all fit on the screen at once. For this purpose, multiple set of windows can be arranged in workspaces.

You can change your active workspace with the number keys, for example:

Shortcut	Function
<i>SUPER</i> +2	Go to workspace 2
<i>SUPER</i> +1	Go back to workspace 1
<i>SUPER</i> + <i>SHIFT</i> +5	Move active window to workspace 5

You can open different spaces for different programs. For example, you might want to put your code-editing programs in workspace 1, a web browser in workspace 2, and some instant messaging programs in workspace 3.

5.2.5 Display Brightness

With Sway, you can set the display's brightness using the `brightnessctl` command or, more conveniently, use one of these keyboard shortcuts:

Shortcut	Function
<code>HYPER+SUPER+1</code>	Decrease display brightness
<code>HYPER+SUPER+2</code>	Increase display brightness

5.2.6 Sway Config File

You can tailor Sway's behavior and keyboard shortcuts by editing the file `~/.config/sway/config` or one of the included files in the `~/.config/sway/config.d` directory.

All configuration options are documented in the manual page that you can access by typing `man 5 sway` in a terminal. More information is also available in the Sway Wiki: <https://github.com/swaywm/sway/wiki>

Some of the most important configuration options are explained in the following sections.

5.2.7 Network, Wi-Fi, and Bluetooth

You can connect to Wi-Fi networks and configure Ethernet as well as VPN connections by clicking the respective buttons in the tray area of the top bar.

On Sway, you'll see a Bluetooth icon in the tray area of the top bar. This icon is powered by the `blueman` package behind the scenes and clicking on it with the left mouse button will open the *Bluetooth Devices* window, where you can search for nearby devices to connect to. Right clicking on a Bluetooth device will give you the options to connect, pair, or get more information. You can also right-click on the Bluetooth icon in the top bar itself to open a context menu with more options,

like toggling the Bluetooth visibility of your MNT Reform, sending files or reestablishing recent connections.

Note that any Bluetooth audio devices, when connected, will appear in *Volume Control* (started by launching it from the speaker icon in the top bar or manually from the launcher). Here you can choose them as the default output or input device and adjust the volume.

5.2.8 Sound

There are multiple ways to change the audio volume:

- Scroll (with the Trackball's Wheel Mode) up and down while the mouse cursor is hovering over the speaker icon.
- Click on the speaker icon in the top bar and select *Volume Control*. In the *Output Devices* tab, you can control the volume with the slider in the *Built-in Audio Speaker* (or *Built-in Audio Headphones*) section.

To change between the built-in Speaker output and headphones, you can use *Volume Control* as well. Go to the *Configuration* tab and select the *Profile* under *Built-in Audio*, either *MNT Reform Hi-Fi Audio (Speaker)* or *MNT Reform Hi-Fi Audio (Headphones)*. The exact names of the profiles can differ depending on your Processor Module.

5.2.9 Keyboard Layout

The keyboard layout is normally configured by the MNT Reform Setup Wizard. Should you want to configure it manually, you can edit the `~/.config/sway/config.d/input` file. For example, the following snippet will change the layout to the EU layout for any connected keyboard:

```
input * {
    xkb_layout eu
    xkb_options lv3:ralt_switch
}
```

5.2.10 Trackball/Trackpad Speed

A common thing that people want to tune to their particular taste is the speed of the trackball (or trackpad) on MNT Reform. For Sway, you could add an `input` section (or extend the existing one) to the `~/.config/sway/config.d/input` file as such:

```
input * {
    accel_profile adaptive
    pointer_accel 1.0
}
```

Where `pointer_accel` can be a number between -1.0 and 1.0.

You can find out about all of the details of Sway's input configuration by opening its manual page using `man sway-input`.

5.2.11 External Displays

Some Processor Modules allow you to connect an external display on the HDMI port, but not all of them can drive both the internal and the external display at the same time. If your module supports dual display, plugging in an external monitor should just work. If you want to configure the placement and resolution of this monitor, take a look at `man sway-output` and create an `output HDMI-A-1` section in your Sway config file. Other helpful tools that you can install for these purposes are `kanshi` and `wlr-randr`.

You can also use `swaymsg` to control your displays on the fly or when pressing certain key combinations. The following example script will switch from internal to external display and force a standard 1080p mode:

```
#!/bin/sh
swaymsg output eDP-1 disable
swaymsg output HDMI-A-1 enable
swaymsg output HDMI-A-1 modeline 148.50 1920 2448 2492\
    2640 1080 1084 1089\
```

1125 +hsync +vsync

5.3 The GNOME Desktop

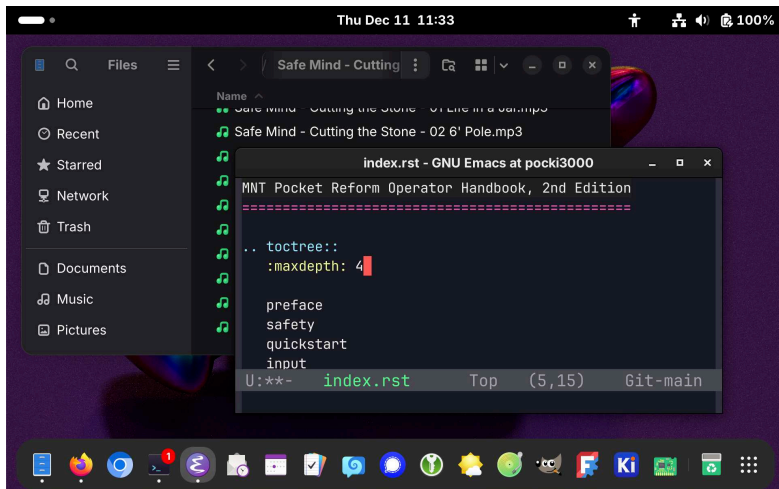

GNOME on MNT Reform supports a number of customized keyboard shortcuts to speed up working with the desktop:

Shortcut	Function
<i>SUPER</i>	Open <i>Activities</i> overview and launch applications
<i>SUPER</i> +← or →	Tile window to left or right
<i>SUPER</i> +↑ or ↓	(Un)maximize window
<i>SUPER</i> +TAB	Cycle through running applications
<i>ALT</i> +TAB	Cycle through windows of the focused application
<i>SUPER</i> +ENTER	Open a terminal
<i>SUPER</i> +ESC	Close the focused window
<i>SUPER</i> +SHIFT+S	Take screenshot (in ~/Pictures)
<i>SUPER</i> +SHIFT+X	Take screenshot of an area
<i>SUPER</i> +SHIFT+R	Make a screen recording of an area
<i>HYPER</i> +F1	Decrease display brightness
<i>HYPER</i> +F2	Increase display brightness
<i>HYPER</i> +F10	Toggle silent volume

Shortcut	Function
<i>HYPER+F11</i>	Decrease volume
<i>HYPER+F12</i>	Increase volume

To speed up your window juggling, you can move windows not only by dragging their titlebar, but also by holding *SUPER* and dragging (with the left trackball button) anywhere in a window. To resize the window from any point, you can hold *SUPER* and drag on the window with the right trackball button.

5.3.1 Launching Applications

With GNOME, you can start an application using the dock (the row of icons on the bottom of the screen, also called *Dash*) or the *Activities overview* (opened by pressing the *SUPER* key). You can find an application by typing a part of its name in the overview. You can pin a frequently used application in the dock by right clicking its icon and choosing "Pin to Dock".

5.3.2 Top Bar

The top bar in GNOME has 3 major sections:

- Left side: Workspaces indicator. If you have multiple workspaces configured, it highlights which one is currently active. Clicking on the indicator brings up the *Activities overview*.
- Middle: Date and time. Clicking on them opens a dropdown with a list of notifications and the calendar. You can set up the calendar using the *Evolution* application (an email client with built-in calendaring and task management) or the more minimalistic *Calendar* application.
- Right side: Accessibility menu, and a combined indicator for network, volume and battery status. Clicking this indicator brings up the *System Menu*.

5.3.3 System Menu: Volume, Brightness, Network

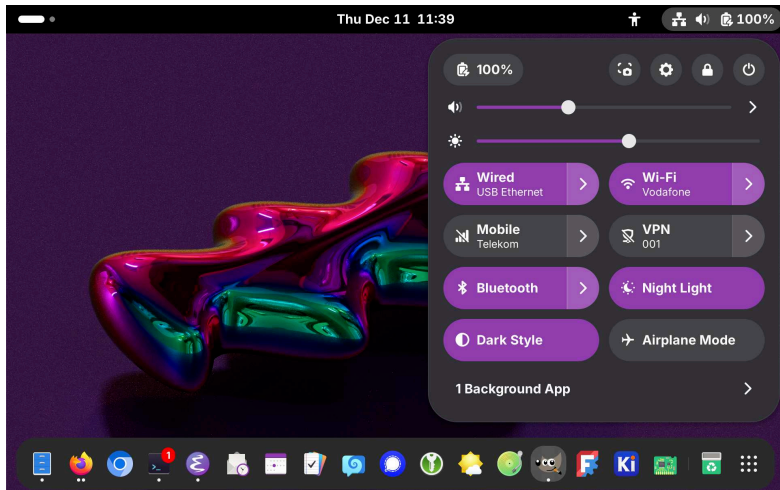

The System Menu lets you control all important settings of the system. From top to bottom:

- Buttons (from left to right):
 - Battery status
 - Taking screenshots
 - Settings
 - Lock screen
 - Power off / Reboot / Log out
- Volume slider
- Display brightness slider
- *Quick Settings*

The *Quick Settings* are a mix of buttons that control network interfaces like Wi-Fi, Ethernet, Cellphone network, Bluetooth. You can connect to your respective networks and devices here, or toggle them on and off. In addition, there are toggle

buttons for the user interface's *Dark Mode*, *Airplane Mode* (which shuts down all radio interfaces) and *Night Light* (to automatically set the display to a more eye-friendly hue at night).

5.3.4 Sound

Beyond adjusting the audio volume, you can also switch between the built-in speaker and headphones (or USB and Bluetooth audio devices) by clicking the arrow icon right next to the volume slider in the *System Menu*. From there, you can also reach the more detailed *Sound* page of the *Settings* application.

5.3.5 Settings: Keyboard Layout, Displays and More

All of the *Quick Settings* can be configured in more detail in *GNOME Settings* (also called `gnome-control-center`), an application that you can access by clicking the gear icon in the *System Menu*. Alternatively, you can find it as a normal application in the *Activities* overview by typing “Settings”.

In addition to networks, you can configure almost all important aspects of the system here. Some of the most commonly needed settings are:

- *Keyboard*: The keyboard layout is initially configured by the MNT Reform Setup Wizard, but you can change it here.
- *Mouse & Touchpad*: Change the speed and behavior of the trackball (or external mouse/touchpad).
- *Sound*: Change audio devices, volumes, and the alert sound.
- *Displays*: Configure display scale and external displays.

There are many additional, hidden settings that don't appear in the *GNOME Settings* application. You can explore them

using `gnome-tweaks` or the `gsettings` command-line tool.

5.4 Alternative Desktops

You're not limited to the desktop options that we include with the System Image. You can install any desktop environment that is packaged in Debian. For example, you can install KDE by entering `sudo apt install kde-standard`, or Xfce4 by entering `sudo apt install xfce4` in a terminal. To switch between desktop environments, click on the gear icon on the GDM login screen after selecting your username (before entering your password).

Please note that installing a heavyweight desktop environment like KDE will affect your existing GNOME installation too, by adding additional services, changing icons/fonts/cursors etc. So this isn't without risk (or at least some cleanup work if you later decide to go back).

Chapter 6

Software

We ship the Reform system in a minimalist form to give you the freedom to decide what you want to install. As we want the device to be practical out of the box, we preinstalled some essential tools, which are listed in the following section. We also included a section about the so-called “Reform Tools”, which are Reform specific helpers and scripts.

MNT Reform can run most Linux applications that are available for 64bit ARM-based computers (also called AArch64 or ARM64).

6.1 Preinstalled Software

Evince View PDFs and other documents.

Command: `evince`

<https://wiki.gnome.org/Apps/Evince>

Firefox Mozilla’s open-source web browser.

Command: `firefox`

<https://www.mozilla.org/firefox>

ptyxis A terminal emulator that is fast, minimalistic, and lightweight.

Command: `ptyxis`

Keyboard shortcut: *SUPER+ENTER*

<https://gitlab.gnome.org/cherbert/ptyxis>

GNOME Disks Partition, format, and manage internal and external disks.

Command: `gnome-disks`

<https://wiki.gnome.org/Apps/Disks>

Grim & Slurp Grim is a wayland-based screenshot tool, and Slurp lets you select the region of the screen you want to capture.

Command: `grim -g "$(slurp)"`

Keyboard shortcut: *SUPER+SHIFT+X*

<https://wayland.emersion.fr/grim>

htop A terminal-based look at system processes, CPU and memory usage.

Command: `htop`

<https://htop.dev>

micro An accessible, fresh terminal-based text editor.

Command: `micro`

<https://micro-editor.github.io/>

Luantı (previously Minetest) An 3D block-based open-world game focused on exploration, resource gathering, and construction.

Command: `minetest`

<https://minetest.net>

MPV A versatile, terminal-based media player.

Command: `mpv a-movie-file.mp4`

<https://mpv.io>

NCurses Disk Usage Terminal-based disk usage analysis utility.

Command: `ncdu`

<https://dev.yorhel.nl/ncdu>

Neverball This 3D game lets you guide a ball through 24 challenging levels.

Command: `neverball`

<https://neverball.org>

Sxiv A simple and fast image viewer.

Command: `sxiv`

<https://github.com/muennich/sxiv/>

Thunar Lightweight file manager.

Command: `thunar`

<https://docs.xfce.org/xfce/thunar/start>

Vim The other major open text editor.

Command: `vim` (Exit by typing `:q` followed by *ENTER*)

<https://www.vim.org>

Wayland Event Viewer Useful when debugging input devices under wayland-based compositors such as Sway.

Command: `wev`

<https://git.sr.ht/~sircmpwn/wev>

Wayvnc Access your MNT Reform desktop remotely from VNC clients on other platforms using this server application.

Command: `wayvnc`

```
https://github.com/any1/wayvnc
```

wf-recorder Record MP4 video of your desktop with this program.

Command: `wf-recorder` (Stop with `CTRL+C`. The resulting video is named "recording.mp4")

```
https://github.com/ammen99/wf-recorder
```

6.2 Updating Software

We recommend updating your software on a regular basis as bugs get fixed, new features are introduced and improvements are made. For this purpose, Debian has an integrated package manager called `apt`. You can stay up to date by executing the following command: `sudo apt update`. This will show you how many packages can be updated. You can either update individual packages using `sudo apt install package-name` or everything at once with one command: `sudo apt full-upgrade`.

You can also use *GNOME Software* to explore and install packages with a graphical user interface. Debian doesn't have all Linux software packaged, and you can find additional software using the `flatpak` command and *Flathub* (an "App Store" for Linux). Please note that *Flathub* packages are not vetted by MNT or Debian and potentially have risks. You can add the software catalog from *Flathub* to *GNOME Software* using the following commands:

```
sudo apt install flatpak
```

```
# the following goes on one line
```

```
flatpak remote-add flathub
```

```
https://dl.flathub.org/repo/flathub.flatpakrepo
```

6.3 Flashing the System Image

If your operating system is broken or you want to set up a new system (for example when upgrading to a new Processor Module), you can create a bootable SD card by downloading the MNT Reform System Image from: <https://mnt.re/system-image>

First of all, back up all your important data! The following process will erase everything that is on the SD card you decide to flash.

From the link above, download the file whose name matches the Processor Module in your MNT Reform:

Processor Module	Filename
NXP i.MX8MQ	reform-system-imx8mq.img.gz
NXP i.MX8MPlus	reform-system-imx8mp.img.gz
NXP LS1028A	reform-system-ls1028a.img.gz
RCM4 with BPi CM4/A311D	reform-system-a311d.img.gz
Rockchip RK3588 (DSI)	reform-system-rk3588-dsi.img.gz
Rockchip RK3588 (HDMI)	reform-system-rk3588.img.gz

Note that the images for MNT Reform are not compatible with MNT Pocket Reform and MNT Reform Next. Also, If you have an MNT Reform with RK3588 shipped in 2025 or newer, you probably don't have the internal HDMI adapter (an extra PCB sitting on the internal display connector of the motherboard, in the top left corner, with a flat cable going to the Processor Module). If you have an HDMI adapter installed, use the the HDMI variant of the image, otherwise use the DSI variant.

Unzip the image using `gunzip` (substitute your actual image file name, also in the following steps):

```
gunzip reform-system-rk3588-dsi.img.gz
```

Identify the device name of your SD card. For example, you can check the output of `lsblk` before and after you insert the card and compare which new device appears. Below

we use the device `sdX`, but it will be a different one on your computer.

Copy the image to your SD card (**Warning: all data on the SD card will be erased!**):

```
sudo dd if=reform-system-rk3588-dsi.img of=/dev/sdX \
      bs=8M status=progress
```

That's it—now you can boot your Reform from the freshly flashed SD card.

As new modules become available, you can refer to our on-line guide: <https://source.mnt.re/reform/reform-system-image#downloading-and-flashing-a-system-image>

6.4 Reform Tools

We have our own Debian package called `reform-tools`. These tools are designed to automate otherwise tedious system configuration tasks, so we encourage you to check them out.

Command	Function
<code>reform-check</code>	Tries to analyze what's wrong with your OS.
<code>reform-display-config</code>	This tool configures single and dual display mode. Only supported with i.MX8MQ.
<code>reform-flash-uboot</code>	This updates the bootloader (rarely needed).
<code>reform-help</code>	Shows you a list of useful commands.
<code>reform-migrate</code>	Helps you with OS migration from SD card to NVMe or eMMC flash.
<code>reform-setup-encrypted-disk</code>	Use this for moving your OS to an NVMe SSD with encryption (recommended).

More information about reform-tools: <https://source.mnt.re/reform/reform-tools>

6.5 Running x86 Software

A popular architecture for computers is x86-64 (a.k.a. AMD64). Binaries compiled for this architecture are normally incompatible with ARM processors. If you want to use binary software, you should make sure that it is built for AArch64 for best performance. The vast majority of open-source software is available for AArch64 (also called `arm64`).

Until RISC architecture will change everything, many games and proprietary closed-source applications are only available as x86 or x86-64 binaries. If you need to run such a binary, you can use a binary translator such as `box64`, which you can install using `sudo apt install box64`.

```
box64 ./my-game
```

You can even run some Microsoft Windows applications on MNT Reform by chaining `box64` and `wine`, which is a Linux compatibility layer for Windows binaries:

```
box64 wine ./my-game
```

Box64 can emulate 32-bit x86 binaries as well. For example, you can install Valve's Steam app using the included script:

```
/usr/share/doc/box64/examples/install_steam.sh
```

Please note that Steam is not open source software.

6.6 GPU Hacks

At the time of writing, most MNT Reform Processor Modules are based on ARM System-on-Chips that contain a GPU meant for mobile or "embedded" use. Multiple factors define the limits of the versions of OpenGL, OpenGL ES and Vulkan APIs that software can use on MNT Reform: for example, the

space- or energy-saving architecture of these GPUs, or the capabilities of the often reverse-engineered open-source drivers such as `etnaviv` or `panfrost`.

Sometimes, graphics heavy applications or 3D games are written with large and power hungry desktop GPUs in mind and require a GL or Vulkan version that is out of reach of your device. In some cases the developers do not really require the features available for higher OpenGL versions, though, and you can try to work around the limitation by pretending that your system supports a higher version than it really does. To do this, you can set the following environment variables in a terminal and then launch your application or game from this same terminal:

```
export MESA_GL_VERSION_OVERRIDE=4.2
export MESA_GLSL_VERSION_OVERRIDE=420
my-game
```

If this fails, you can always fall back to software emulation of OpenGL, which will be slow but sometimes usable:

```
export LIBGL_ALWAYS_SOFTWARE=1
my-game
```

Mesa is the collection of Linux 3D graphics drivers. You can learn more about various Mesa environment variables at <https://docs.mesa3d.org/envvars>

Chapter 7

Hardware

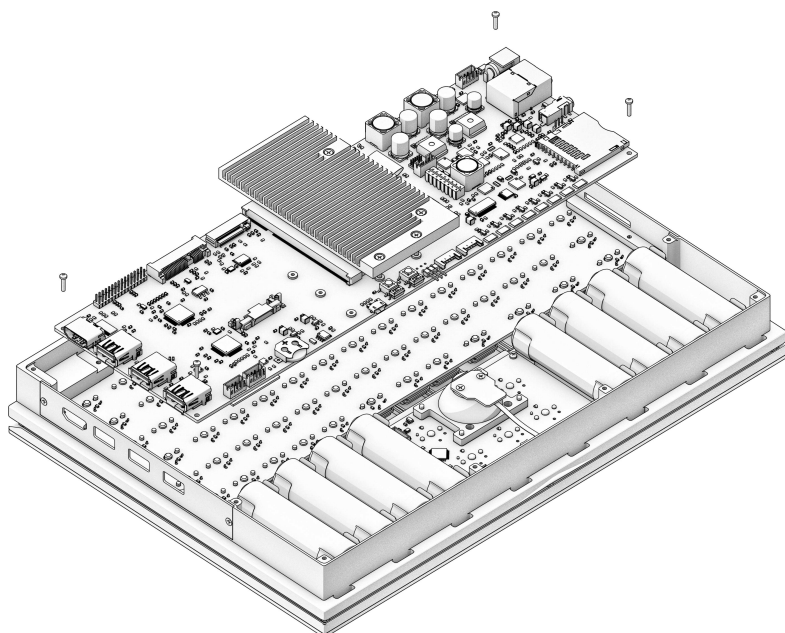

7.1 Case Parts

The case consists of the following 5 parts. All parts except the Bottom Plate are milled from sand-blasted and anodized 6061 aluminum.

1. **Main Box:** the chassis of MNT Reform. All PCBs (printed circuit boards) are attached to it via screws: The keyboard from the top and motherboard, trackball/trackpad, and battery boards from the bottom. The lower half of the hinges and the system controller OLED PCB are mounted from the top as well.
2. **Keyboard Frame:** a thin rectangle that covers the sides of the keyboard and the system controller OLED
3. **Screen Back:** houses the display and upper half of hinges
4. **Screen Front:** houses speakers and providing display bezel
5. **Bottom Plate:** the clear acrylic plate that closes the laptop from the bottom

For easy (dis)assembly, Reform uses M2 screws with Phillips-head everywhere—with one exception: M4x5 on the top half of the hinges.

7.1.1 Main Box

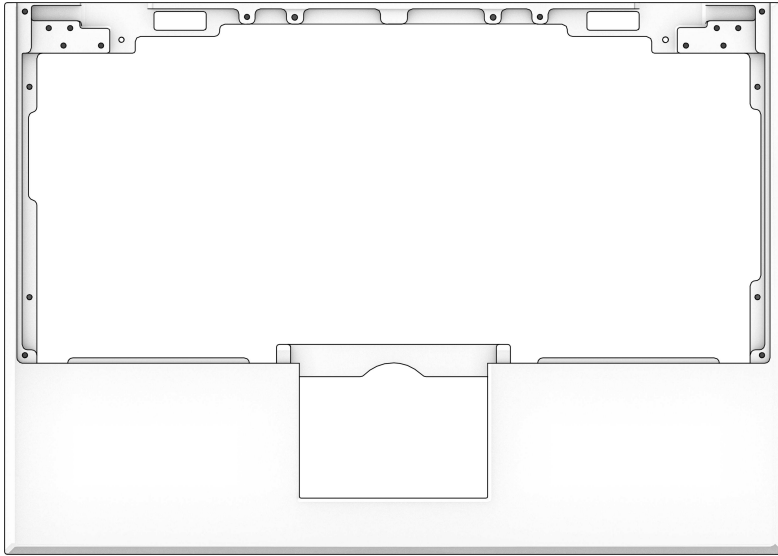

The Main Box houses most of the electronics:

- Motherboard, exposing ports through openings on the left and right
- Two LiFePO₄ battery packs, connecting to the motherboard via Molex PicoLock cables
- Keyboard, connecting to the motherboard via two JST-PH cables
- OLED display, connecting to the keyboard via a 4-pin 1mm pitch flex cable
- Trackball or Trackpad, connecting to the motherboard via one JST-PH cable

The Main Box features four neodymium bar magnets inserted into slots below the front edge. These match with their counterparts in the Screen Front.

7.1.2 Keyboard Frame

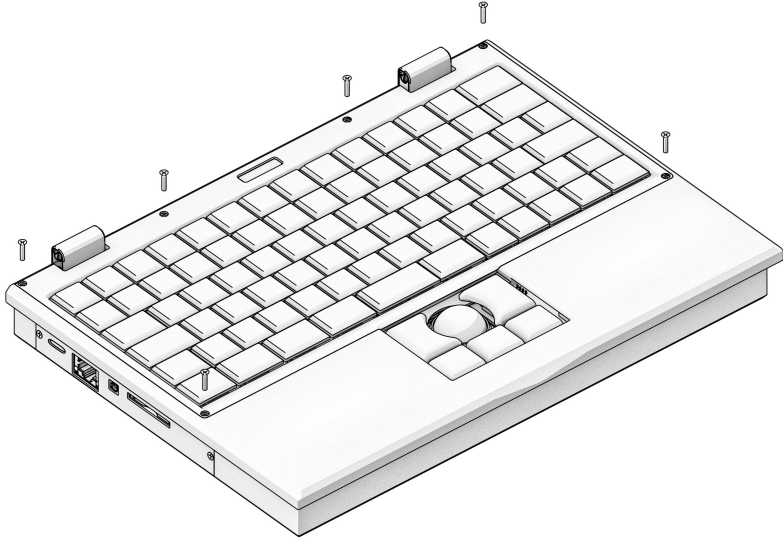

The Keyboard Frame is inserted into the Main Box. It has four tabs on the front that must be inserted first. The frame is mounted with six black M2x5 countersunk screws.

7.1.3 Screen Back

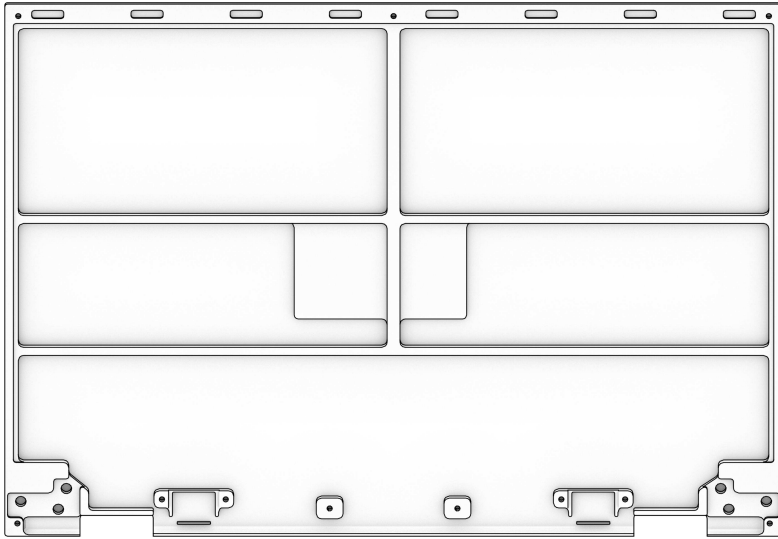

The eDP display panel rests in the Screen Back. The left and right hinges are mounted in the bottom left and right corners with three M4x5 countersunk screws each. Note that the hinge labeled "SMS-ZZ-219-L" goes on the right side, and the hinge labeled "SMS-ZZ-219-R" goes on the left side. The other half of each hinge is mounted to the Main Box with four M2x6 countersunk screws.

Four neodymium magnets are mounted along the top edge of the Screen Back. These, together with their counterparts in the Main Box, hold the laptop shut when closed.

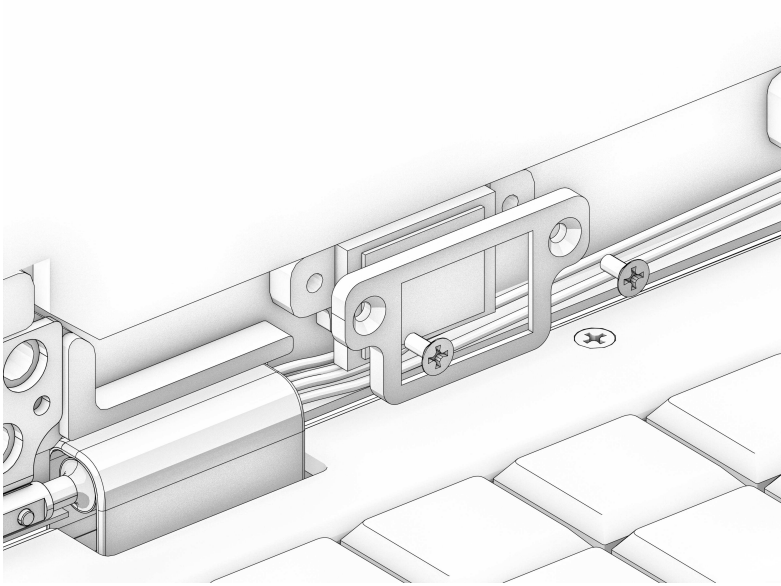

The stereo speakers are mounted below the display and secured with the speaker holders. Each holder is mounted with two black M2x5 countersunk screws. Both speaker and display cable are fed through a cutout in the hinge and into the Main Box.

7.1.4 Screen Front

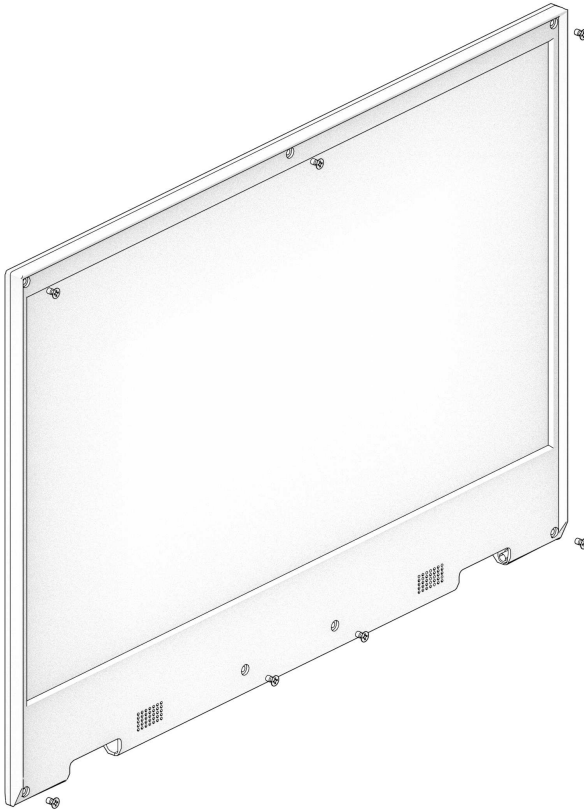

This part serves as a bezel for the display. It is mounted with seven black M2x5 countersunk screws to the Screen Back.

7.1.5 Bottom Plate

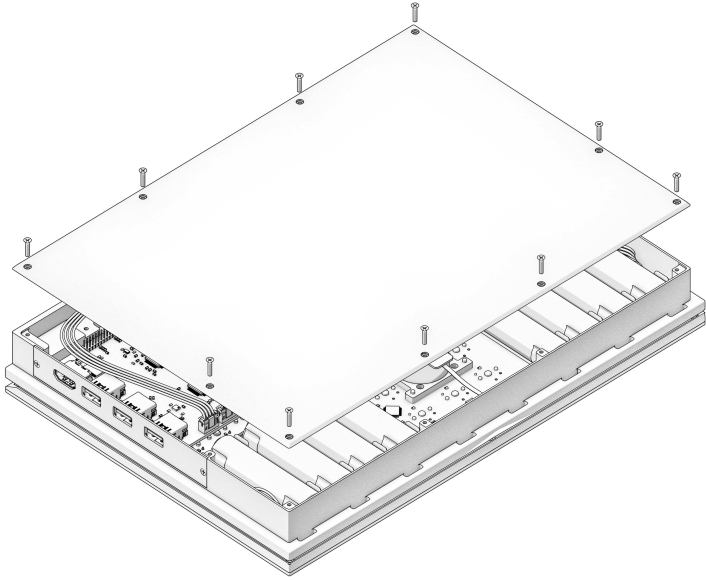

The Bottom Plate closes the Main Box from the bottom with ten M2x6 countersunk screws.

7.1.6 Port Covers

USB-C Power Delivery

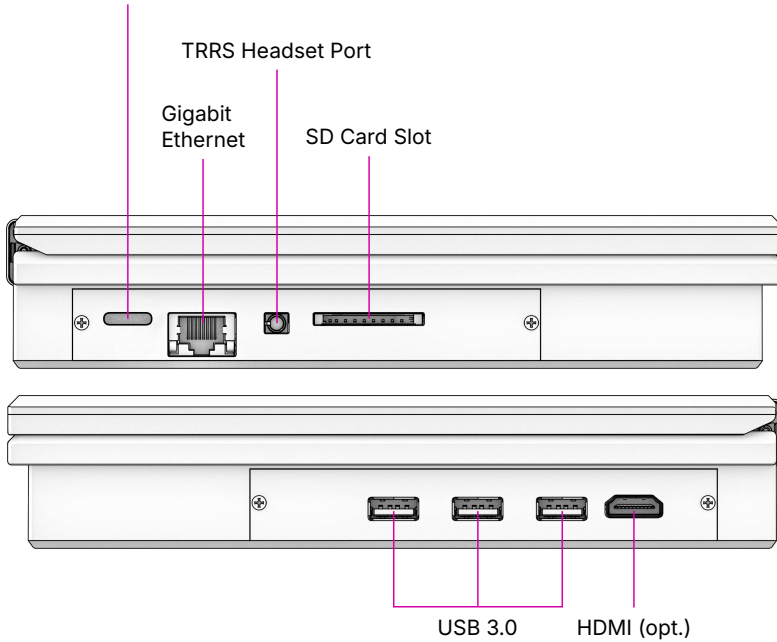

The Port Covers are two pieces of powder coated steel that cover the side openings of the Main Box (mounted with two black M2x5 screws each). You can exchange these to fit a future motherboard or an expansion that requires a different port layout.

7.2 Motherboard

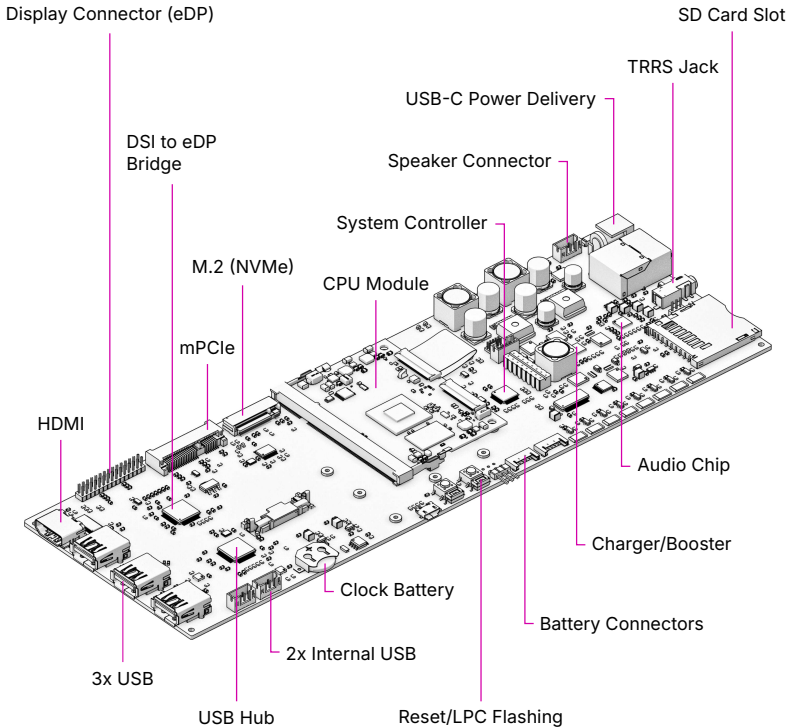

The Motherboard spans the inner width of the device and has outward-facing ports on both sides. It is mounted to the Main Box with four M2x4 pan head screws. The Motherboard has the following main features:

- **Power system:** based on the LTC4020 buck/boost converter, it regulates charging of the LiFePO₄ batteries and seamlessly switches between wall and battery power.
- **System controller:** coupled to the power system, an NXP LPC11U24 Cortex-M0 MCU controls an analog monitor chip for the eight battery cells as well as the charger. It is connected to the Processor Module via SPI,

and has GPIO lines to the main power rail switchers in the system. It has a UART (SYSCTL) that the keyboard can talk to directly for issuing power on/off commands and battery status queries.

- **DSI to eDP bridge:** The SN65DSI86 chip converts the MIPI-DSI output from the Processor Module to an embedded DisplayPort (eDP) signal that the display panel can understand. Some Processor Modules don't make use of this chip, because they can output eDP directly (like the LS1028A) or use an internal HDMI to eDP adapter instead. Please refer to your Processor Module's manual for the details.
- **USB 3.0 hub:** The Processor Modules themselves have two USB ports. To provide for a total of five USB ports (two internal and three external), there is a TUSB8041 USB hub chip on the motherboard that provides the extra ports. USB load switches on each external port protect the system from too much current draw.
- **Sound chip:** A Wolfson/Cirrus WM8960 audio DAC (digital-to-analog converter)/amplifier interfaces to the headphone/microphone jack and powers two speakers housed below the main display.
- **mPCIe slot:** An mPCIe connector that you can use for expansions like a Wi-Fi card or for an NVMe SSD using an M.2 adapter.
- **M.2 slot:** An NGFF slot (Key M) that can either house an NVMe SSD (solid state disk), or with the LS1028A module, a SATA SSD. With some other Processor Modules, this port is inactive (refer to the Processor Module's manual).

7.2.1 Revised Versions

At the time of writing, 3.0 is the latest motherboard version. It is a revised version of the 2.5 Reform motherboard, and it is compatible with all our Processor Modules.

Changes in Version 3.0:

- Replaced Barrel jack with USB-C power delivery input (via firmwareless TPS25730)
- Added USB-UART chip that offers CPU debug consoles and system controller debug UART on that same USB-C port (CY7C65215)
- Replaced old 5V and 3.3V main buck converters with modern ones from Reform Next (LM62460)
- Added direct power input header for custom power solutions like solar
- Bumped NVMe SSD slot from 1x to 4x PCIe lanes (for RK3588)
- Updated PCIe reference clocking chip for PCIe Gen 3 support
- Fixed headphone jack detection (resistor update)
- Fixed/limited LTC4020 charge current overdraw (resistor R8 replaced with 7.15k)
- Redid 5V power rails for USB for higher current and increased capacitance to handle more USB device power draw
- Upgraded USB hub from TUSB8040 to TUSB8041
- Removed unnecessary internal 5V and 3.3V power switches
- Added QwiiC port for I2C expansion via LPC (for example for sensors)
- Added QwiiC port for I2C expansion via CPU
- Replaced SD card slot model
- Updated 1.8V LDO for more modern one
- Removed some unnecessary/unused resistors, signals, and headers

- Improved/redrew some routing and ground fills
- Replaced 3.3V LDO for USB-UART with buck converter

Changes in Version 2.5:

- Lowered headphone lowcut filter for improved bass response
- Replaced Micro-USB with USB-C as the LPC flashing connector
- Lowered power LED brightness
- Fixed current leak through balancing circuit that could bypass missing cells
- Fixed main buck converter enable behavior under low voltage condition
- Fixed charger control circuit that previously required a factory resistor bodge

7.2.2 System Controller

Independent from the main Processor Module, a low-power processor sits on MNT Reform's motherboard. The NXP LPC11U24 is a 32-bit ARM Cortex-M0 processor that uses very little power and is always on as long as there is battery or wall power present. We call this processor the System Controller.

The System Controller runs a program in an endless loop that has the following jobs:

- Powering the individual voltage rails of the system on and off
- Hard resetting the main processor on demand
- Monitoring the voltage of each battery cell
- Balancing battery cells. If a cell is overvoltage, charging is halted and the overvoltage cells are discharged until they are back to a nominal voltage

- Turning off the system if battery cells are undervolted
- Reporting total current flowing in and out of the batteries
- Turning charge current on or off

Your main way of communicating with the System Controller is with the Keyboard. The Keyboard has, aside from its USB connection to the main processor, a second serial (UART) connection/cable to the motherboard's SYSCTL port. A 57600 bps connection is always established between the Keyboard and the System Controller.

It accepts commands in the form of a single letter followed by carriage return (0x0d). A command can also be prefixed with a single argument, a positive integer of up to 4 digits. The most important commands are:

Command	Function
<i>1p</i>	Turn the computer on
<i>0p</i>	Turn the computer off
<i>a</i>	Get current flowing into/out of batteries in mA
<i>v</i>	Get cell voltage statistics
<i>V</i>	Get combined battery voltage
<i>s</i>	Get System Controller state (a message string)
<i>g</i>	Get estimated "fuel gauge" of batteries (percentage)

The individual cell voltages are measured by the Battery Monitor LTC6803IG-4#PBF and reported via SPI to the System Controller. The total voltage and current are measured by the INA260 chip and reported via I²C.

To understand the available commands in more detail, you can take a look at the System Controller's `handle_commands()` function.

The System Controller is connected to the Processor Module through a SPI interface and through an auxiliary UART. The System Image ships with a kernel module called `reform2-lpc` which makes battery information available to the OS. The

source code for this module is available in the `reform2-lpc-driver` directory of the Reform repository.

7.2.3 Flashing the Firmware

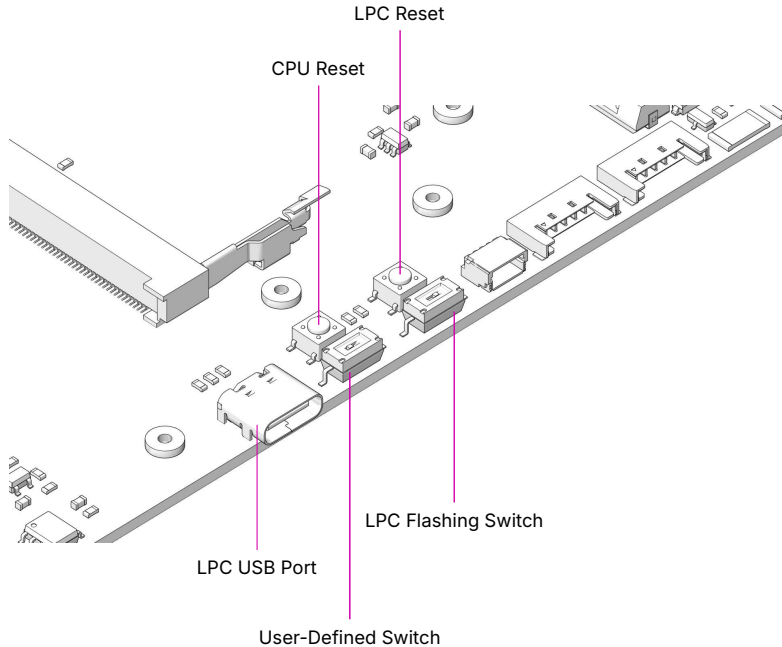

To update (flash) the firmware of the System Controller, you need another computer and a USB-C cable (or, if you have a motherboard older than version 2.5, a Micro-USB cable).

You can find the source code of the firmware and a script that guides you through the flashing process in MNT Reform's source folder `reform2-lpc-fw`.

On your other computer, execute the following commands:

```
git clone https://source.mnt.re/reform/reform
cd reform/reform2-lpc-fw
./download-fw.sh 30_R1
sudo ./flash.sh
```

If you have an older motherboard version, substitute `30_R1` above for the appropriate version number. You can see all version numbers by running `./download-fw.sh` without any arguments.

The `flash.sh` script will interactively guide you through the necessary steps. These are:

1. Open MNT Reform's lid and remove the batteries.
2. Connect the charger. Be very careful to avoid shorts from this point on.
3. Set DIP switch `LPCPROG` (LPC Flashing Switch) on MNT Reform's motherboard to "ON".
4. Press button `LPCRESET`.
5. Connect USB-C (or Micro-USB) cable between MNT Reform's motherboard and your other computer.
6. System Controller's memory appears as a virtual flash drive. The `flash.sh` script will recognize it and copy the `firmware.bin` to this virtual drive.
7. Unplug the USB-C or Micro-USB cable.
8. Set DIP switch `LPCPROG` (LPC Flashing Switch) to "OFF" (labelled "1" on the switch).
9. Press button `LPCRESET`.
10. Disconnect the charger and reassemble your MNT Reform.

Alternatively, you can build the firmware yourself. Please follow the instructions in the `README.md` file to do so.

7.2.4 Expansion Port

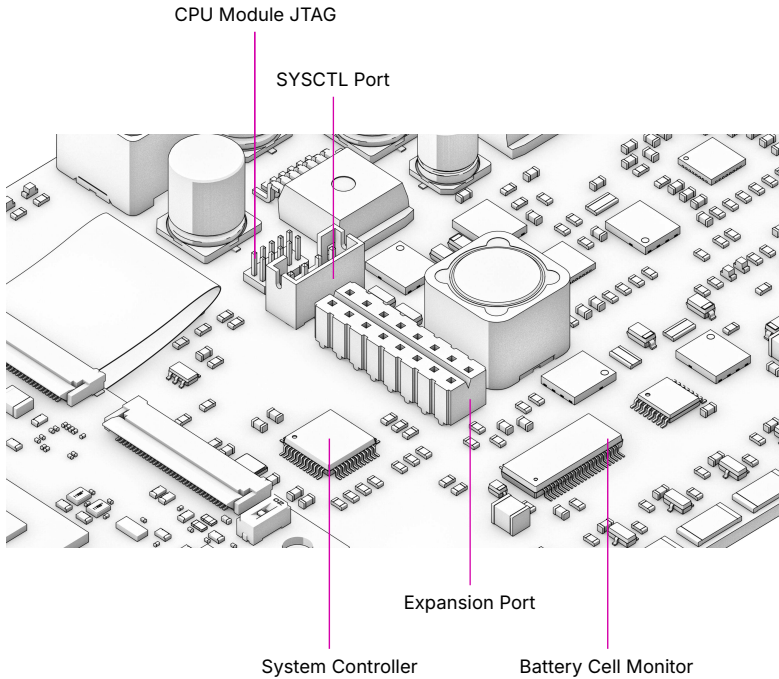

The Expansion Port U18, labeled “Hack the Planet” is meant for advanced users that want to connect sensors or other peripherals to MNT Reform’s system controller. Please note that changing the system controller’s program can disrupt the battery charging control loop, potentially causing over- or undercharged cells, resulting in physical damage and/or injury. **Experiment with the system controller only if you know exactly what you’re doing and at your own risk.**

The Expansion Port features an SPI interface, two analog-digital converters, a UART, JTAG and 3.3V Power. All non-power pins can alternatively be used as GPIOs.

The following LPC11U24 pins are available at the port:

Pin	Function	Pin	Function
16	GND	15	3.3V
14	MOSI1a	13	USBCON#
12	RXDa	11	TXDa
10	AD7	9	SCLKa
8	SWDIO	7	AD5
6	TDO	5	TRST#
4	TDI	3	TMS
2	MISO1a	1	SCK0b

Refer to the motherboard schematic's *Power* section and the NXP LPC11U24 reference manual for further details.

7.2.5 mPCIe Socket

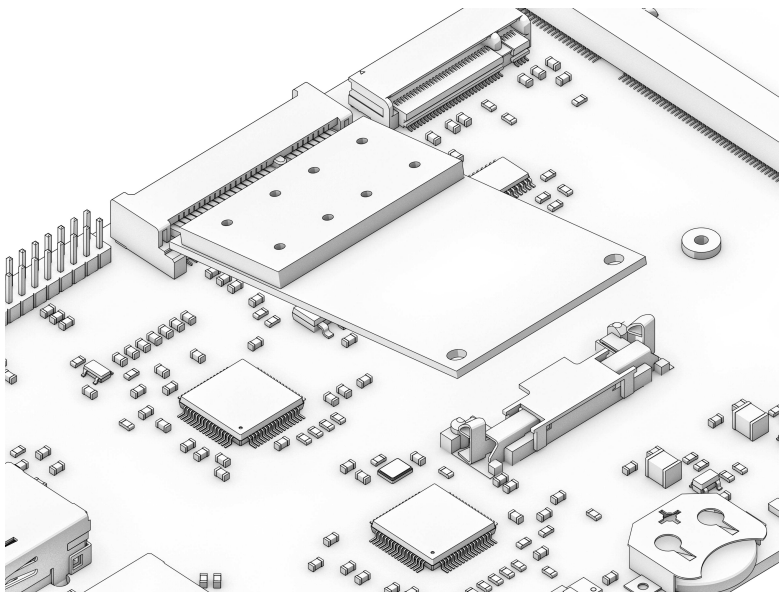

All Processor Modules feature at least one PCIe controller which is connected to the mPCIe socket U11. The standard use for the mPCIe port is a WiFi card or an NVMe SSD (with

M.2 adapter). To install a card, plug it into the socket at an angle and then press down the opposing side into the latch. To remove the card, just pull on the two protruding metal springs of the latch and the card will pop out.

The reference clock of the mPCIe slot is provided by the Processor Module.

7.2.6 M.2 Socket (Key M)

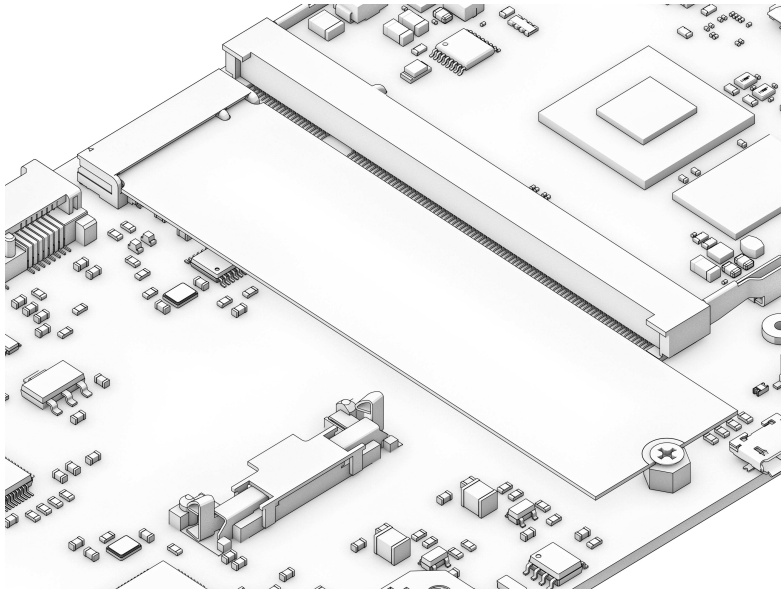

Some Processor Modules, such as the original i.MX8M module and the RCORE with RK3588, feature a second PCIe controller—or in the case of LS1028A, a SATA controller—which is connected to the M.2 socket (J10). The standard use for the port is to install an M.2 NVMe solid state drive. Plug the SSD disk into the socket and fix it with an M2 screw to one of the three mounting holes that corresponds to the module's size.

The reference clock for the port is generated by U23 on the

motherboard.

7.3 Processor Module

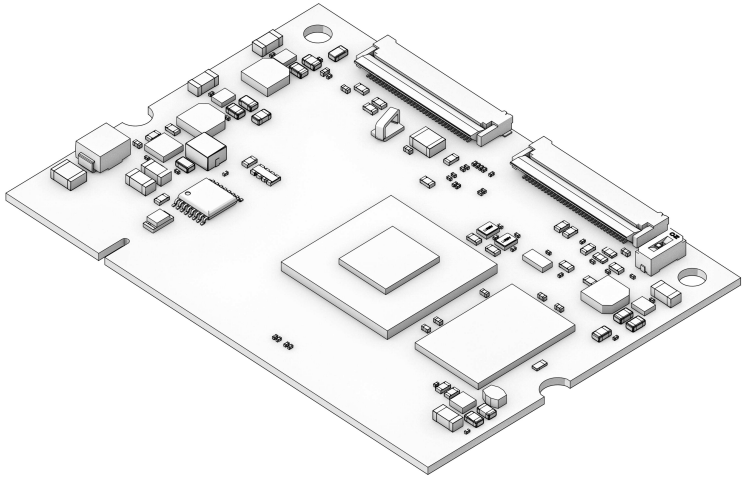

When the first edition of this handbook was released, we had only one Processor Module to offer. Now, nearly four years later, there are several of them, each with different features to accommodate individual preferences. We are constantly developing new modules for Reform, the latest drop being RCORE with RK3588—a powerful Processor Module that gives you 4x performant ARM Cortex-A76 cores, 4x power-efficient ARM Cortex-A55 cores, and up to 32 GB RAM.

The Processor Module is plugged into motherboard connector U1 which has 200 pins. If you want to learn more about Reform’s Processor Modules, take a look at the schematics and source KiCad projects in our GitLab repository.

If you want to develop your own Processor Module, visit <https://source.mnt.re/reform/reform-som-template> for a KiCad template and more technical information.

7.3.1 Display Connector

The default display in MNT Reform conforms to the eDP (embedded DisplayPort) standard. Some Processor Modules, such as i.MX8M and RCM4, output a MIPI-DSI signal on its flex connector that is fed into the J24 connector on the motherboard using the 30 pin, 0.5mm pitch flex cable. The SN65DSI86 chip on the motherboard converts the MIPI-DSI signal to eDP. If you use a different Processor Module that outputs eDP directly, the J24 connection is skipped. Refer to the manual of your module instead.

7.4 Heatsink

The heatsink is a piece of milled aluminum that connects to the silicon die of the main SoC on the Processor Module, with a thermal pad applied on the die. The heatsink is fixed to the motherboard by four M2x12 screws. The screws are supported by four metal or plastic spacers.

7.5 Keyboard

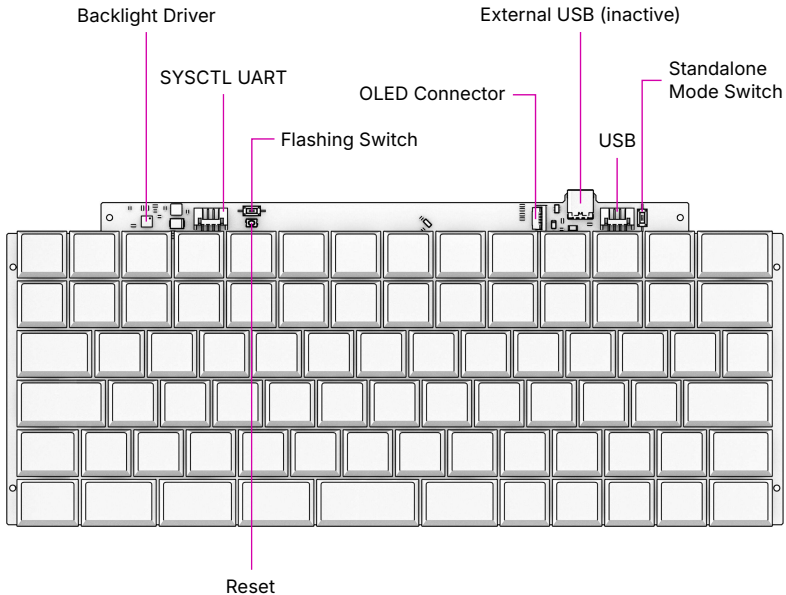

The keyboard is mounted to the top of the Main Box with six M2x4 pan head screws. It is powered by an RP2040 microcontroller. The controller scans the row/column matrix of keyswitches and reports key presses via USB HID (human interface device) to the motherboard. Each switch has a diode to prevent ghosting, so you can press multiple keys at once. The microcontroller runs a firmware based on `pico-sdk` and `tinyusb` which is an open source library for implementing USB input devices.

The second role of the keyboard is to serve as a user interface to the LPC system controller on the motherboard, even when the main SoC is turned off. To make this possible, the keyboard connects via a separate UART cable to the motherboard's SYSCCTL header (J23).

The keyboard can also be taken out of the laptop and used as a standalone USB-C device. To enable this function, turn

on the *STANDALONE* switch near the top right corner. When using the keyboard in the laptop, this switch has to be turned off.

7.5.1 Keyboard Firmware

You can update the firmware of the keyboard on MNT Reform itself, but make sure to read this section in full to avoid ending up in a situation where you have to disassemble the laptop.

You'll need an external USB keyboard to finish the process, as your laptop's keyboard will stop responding after entering firmware update mode. Otherwise, you can only recover from this mode by opening the laptop and pressing the keyboard's reset button or disconnecting and reconnecting the battery or keyboard cables.

To be able to flash the firmware to the keyboard, its microcontroller has to be in this special programming mode. Since the 3.0 revision of the Keyboard, you can put it in programming mode by pressing the *Circle* key followed by the *X* key.

For keyboard 4.0 (with RGB backlight), execute these commands:

```
git clone https://source.mnt.re/reform/reform
cd reform/reform2-keyboard4-fw
./download-fw.sh laptop-us
sudo ./flash.sh
```

Substitute `laptop-us` with `laptop-intl` if you have a non-US keyboard layout.

For older keyboard versions (white backlight):

```
git clone https://source.mnt.re/reform/reform
cd reform/reform2-keyboard-fw
./download-fw.sh 3_US # or 3 if you have a
                      # non-US keyboard
                      # or 2 if you have an
```

```
# older pre-V3 keyboard  
sudo ./flash.sh
```

You can find MNT Reform keyboard firmware sources for the current version with RGB backlight in the source folder `reform2-keyboard4-fw`.

MNT Reform keyboard firmware sources for older versions of the keyboard are in the source folder `reform2-keyboard-fw`.

7.5.2 Backlight

Most keys have a light emitting diode (LED) to illuminate the transparent part of the keycaps, making the laser engraved letters visible in darkness. You can control the backlight's brightness via *Circle* followed by *F1* or *F2*, or use the OLED menu. To change the backlight's color on MNT Reforms with keyboard 4.0, you can use *F3/*F4** for hue and *F5/*F6** for saturation control while the OLED menu is open.

7.5.3 Replacing a Keycap

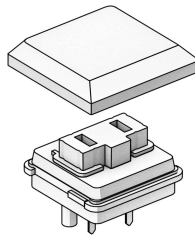

MNT Reform comes with custom *MBK Choc Glow* keycaps by FKcaps, but you can use any keycaps compatible with Kailh Choc keyswitches. You can pull out individual keycaps with your fingernails—or better, using a keycap puller—and swap them around.

7.5.4 Replacing a Keyswitch

Should a keyswitch ever break, you can replace it with Kailh Choc Brown (CPG135001D02) or Kailh Choc White (CPG135001D03).

The best way to desolder the switch is a desoldering gun. If you don't have one, use a soldering iron and solder wick to remove the solder of one pin. Try to pull out the corresponding side of the switch from the top while continuing to heat the pin. Repeat the same for the other pin and go back and forth until you can remove the switch.

7.6 OLED Module

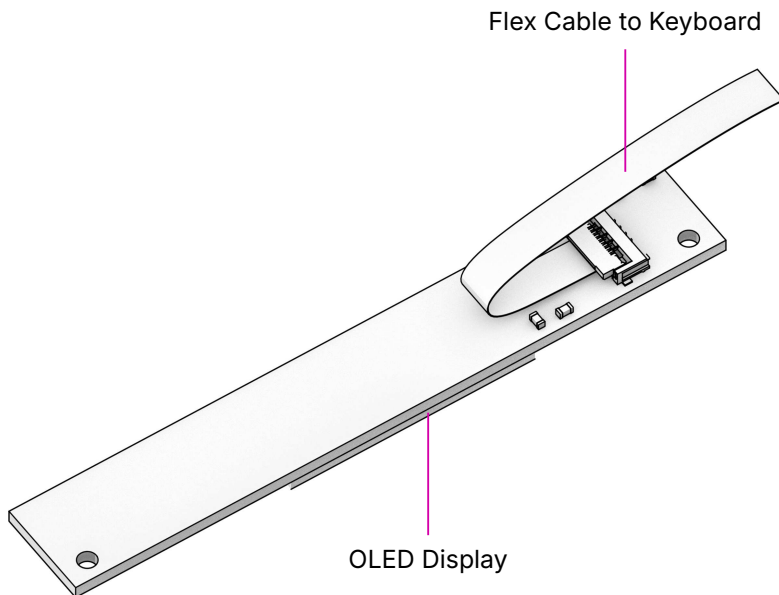

The OLED display sits on the OLED Module which is connected to the keyboard through a 4-pin, 1mm pitch flex cable. The communication protocol is I²C. The module is mounted in the Main Box on top of the keyboard with two

M2x4 pan head screws.

If you're feeling creative and want to customize your OLED with text, images or even animations, we've got you covered. Check the MNT Reform source repository and navigate to the `reform2-keyboard-fw/kbdgfx-demo` directory. This directory contains example code that serves as a starting point for developing your own custom OLED graphics.

7.7 Trackball

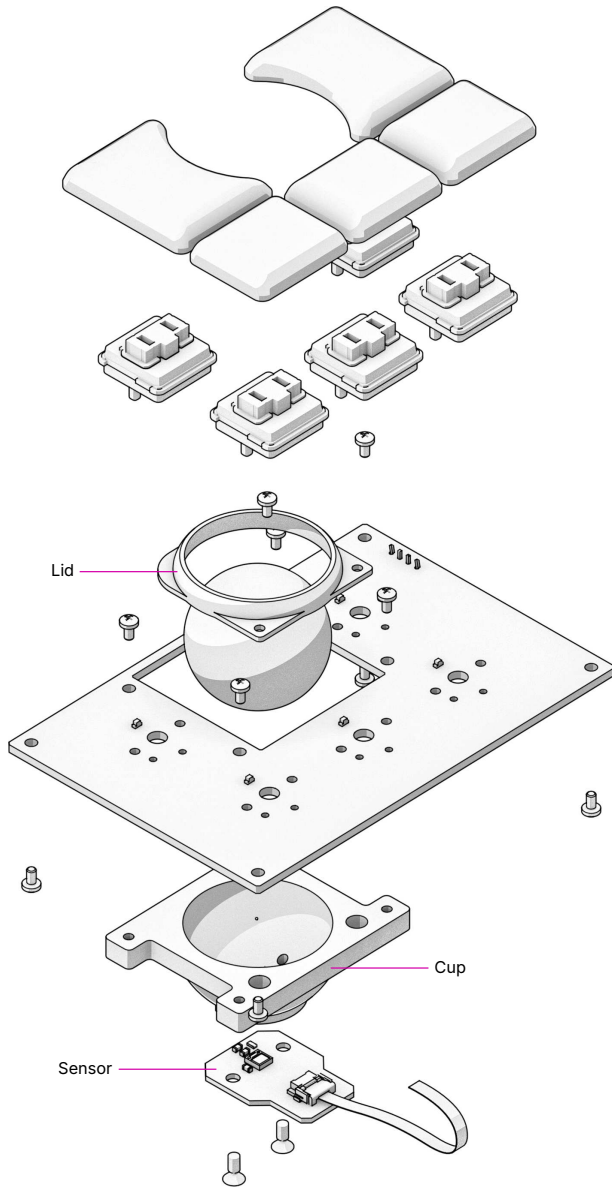

The trackball uses an RP2040 microcontroller to convert X and Y movement coordinates from the PAT9125EL optical sensor that is connected via I²C to the USB HID Mouse protocol. The electronic connection between trackball sensor and controller is made with a 6-pin 0.5mm pitch flex cable.

The trackball has five buttons. These make use of the same keyswitches as the keyboard: Kailh Choc Brown (CPG135001D02). The button caps are 3D printed using SLA resin technology. If you want to substitute your own replacements, you can find the STL files for the caps in the MNT Reform source repository. The cup and lid of the trackball are 3D printed using the same method.

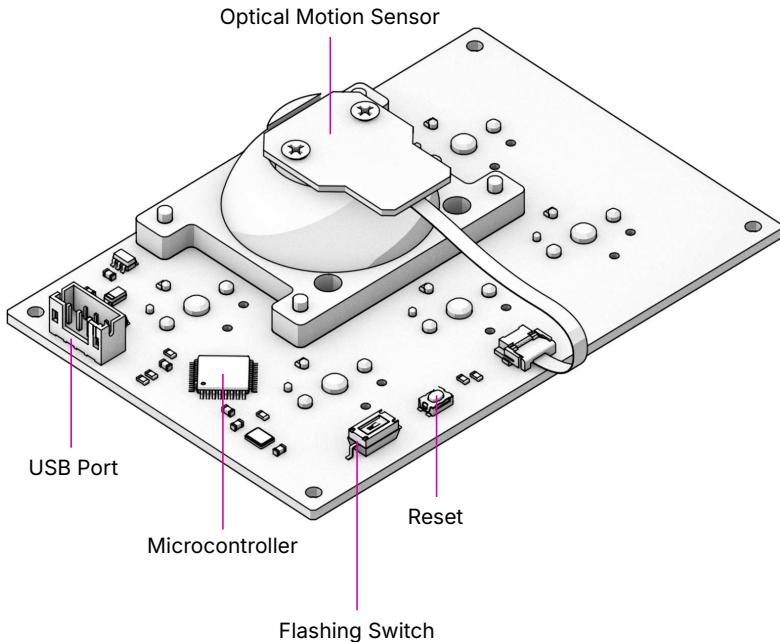

7.7.1 Trackball Cleaning

From time to time, you should clean dust and debris from the trackball. To do this, carefully lift off the left and right buttons.

Then, unscrew the two screws holding the trackball's lid and remove the ball. Clean the inside of the cup with a soft cloth. Don't use detergents as these can dissolve the cup's material.

7.7.2 Trackball Firmware

You can find the trackball firmware in the source folder `reform2-trackball2-fw`, except if you have an older version of the trackball that uses an ATmega32U2 controller instead of a RP2040. The older versions firmware is in the `reform2-trackball-fw` directory. Please refer to its `README.md` file for building and flashing information.

You can download and flash the firmware as follows:

```
git clone https://source.mnt.re/reform/reform
cd reform/reform2-trackball2-fw
./download-fw.sh
sudo ./flash.sh
```

If you want to modify the behavior of the trackball, refer to the `README.md` file in the firmware directory.

7.8 Trackpad

The trackpad integrates an Azoteq TPS65-201 capacitive sensor which reports coordinates to the microcontroller via the SPI protocol.

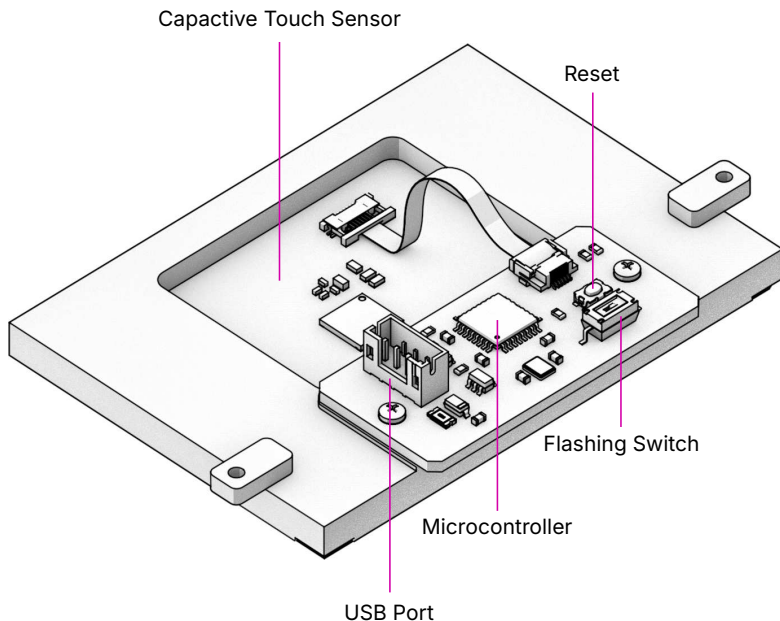

7.8.1 Trackpad Firmware

You can find the trackpad firmware in the source folder `reform2-trackpad-fw`.

Same as the keyboard, the trackpad firmware is based on the LUFA USB device library and implements a USB HID Mouse.

To update the firmware, the MCU has to be in bootloader USB mode. If you have a recent enough trackpad firmware, the flashing script can put it in this mode directly. If this doesn't work, you have to open your MNT Reform and toggle the programming DIP switch SW7 on the trackpad to "ON" and press the reset button SW6. The trackpad will reappear as an "Atmel DFU bootloader USB" device. You can then download and flash new firmware by executing:

```
git clone https://source.mnt.re/reform/reform
cd reform/reform2-trackpad-fw
```

```
./download-fw.sh  
sudo ./flash.sh
```

If you want to modify the behavior of the trackpad, refer to the README.md file in the firmware directory.

7.9 Exchanging Trackball and Trackpad

You can swap the Trackball for the Trackpad module and vice versa. To do this, first disconnect the wall power and flip MNT Reform on its back. Unscrew the Bottom Plate and remove all battery cells. Unplug the side of the internal USB cable that is connected to the installed module. Then, unscrew the module's case mounting screws (four M2x4 pan head screws for the Trackball, two M2x4 pan head screws for the Trackpad) and pull out the module.

Reverse the process to install the new input device. The Trackball is inserted so that its four mounting holes line up with four matching holes in the Main Box. The Trackpad slides into a slot in the Main Box with one end first (the end without mounting tabs) and is then mounted to the Main Box with two screws that go through the tabs on the other end. After mounting the desired module, reconnect the internal USB cable to it.

7.10 Battery Packs

MNT Reform has two identical battery packs, referred to as the Left and Right packs. Each pack holds four 18650 LiFePO4 cells (3.2V). The two packs are mounted to the Main Box with four M2x4 pan head screws for each battery pack.

You may be tempted to try cells of other chemistries like Li-Ion or NiMH, but never do this, as these are incompatible.

Only use LiFePO4 cells with MNT Reform!

When inserting battery cells, make sure that the positive and negative poles are facing in the correct direction. The

poles are marked on the silkscreen of the battery pack PCBs.

All 8 cells are connected in series. When fully charged at 3.6V, the total voltage of the cells can add up to 28.8V. **Make sure not to bridge/short any battery clips to the case or neighboring clips or pins, as this will immediately cause sparks and burnt traces.**

Remove all battery cells before doing any work inside MNT Reform to prevent damage from accidental discharge.

LiFePO4 cells are safely discharged to 2.5V. Please make sure not to discharge the cells further. Since 2022, MNT Reform ships with protected battery boards. These allow you to leave your MNT Reform turned off/uncharged for as long as you need.

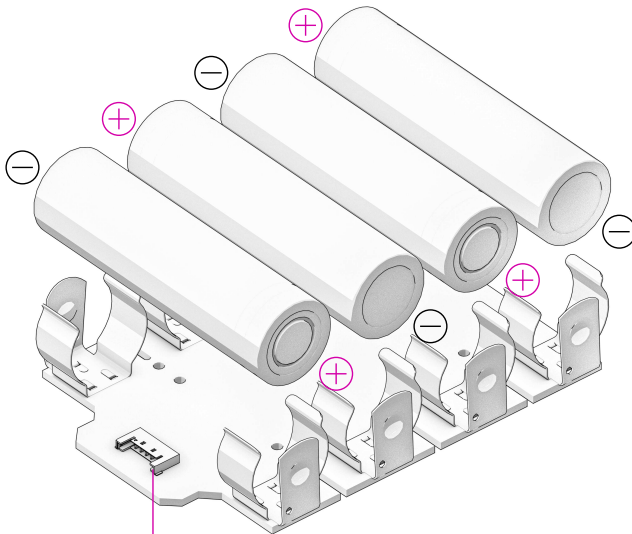

Battery Pack Cable Connector

7.10.1 Compatible Battery Cells

The following table lists compatible LiFePO₄ cells, but any LiFePO₄ chemistry cell of 18650 size should work. It is not recommended to mix cells of different capacities, as the lowest capacity cell will dictate the lowest safe point of discharge.

Brand	Model	Capacity
JGNE	JGCFR18650-2200	2200mAh
Eremit	18650 LiFePO ₄	2000mAh
IFR	18650 LiFePO ₄	1400mAh

7.11 Compatible Displays

MNT Reform was designed to be compatible with a number of 13.3 inch (diagonal) 1920x1080 pixel eDP displays. We tested the following display models successfully:

Brand	Model
Innolux	N125HCE-GN1 (Center Connector)
Innolux	N125HCE-GN1 (Side Connector)
Innolux	N125HCE-GPA (glossy or matte)
BOE	NV125FH1-N82
AU Optronics	B125HAN02.2

Chapter 8

Advanced Topics

A computer is a complex system where hardware and software interact, and sometimes, unpredicted problems may appear. Most issues can be fixed, and in this chapter we will show you how.

This is for advanced users only. If you are unsure about what you are doing, we encourage you to get in touch with our MNT Community or our email support (support@mntre.com).

8.1 Troubleshooting

There are some steps you can try if MNT Reform should stop booting. As always, before working with MNT Reform internals, first disconnect the internal battery and external power and peripherals.

8.1.1 Boot Issues

What can you do if your MNT Reform doesn't boot?

There are several steps you can take to determine the cause.

First of all, check if it has power. If you are in luck, a cable or a connector is just loose and you can plug it back in. Since motherboard version 3.0, the system is powered by USB-C power delivery. So you can use a USB-C PD power monitor to check if there is current flowing into the board, or if there's trouble during USB-C power negotiation.

If this doesn't work, take a look at the OLED screen. Does it show anything when you press the *Circle* key for at least 2 seconds? If not, this could have several reasons:

The OLED module or the two cables of the keyboard may not be fully connected. It is also possible that the keyboard or the mainboard are defective. You can check the functionality of your keyboard by taking it out of the laptop, turning the *STANDALONE* switch on and connecting it to another computer using a USB-C cable. If it doesn't work on another computer, then the keyboard is most likely the reason why your Reform doesn't boot.

If the keyboard is working, but your MNT Reform still doesn't boot, check the battery status page in the OLED menu. Do the 8 battery cells have appropriate voltages between 2.5V and 3.6V? If not, it might be time to exchange the batteries for new LiFePO4 18650 batteries, or trying to boot completely without batteries.

If everything looks OK in terms of power, you can try booting the system from an SD card. If you have another computer at hand, install the latest MNT Reform System Image on an SD card. Refer to the chapter "Software" and the section "Flashing the System Image" in this handbook.

Insert the freshly flashed SD card and try to boot MNT Reform. If this isn't successful, the motherboard or the Processor Module could be defective. If you have another Processor Module and knowledge of how to swap it, you could try this. We recommend getting in touch with our customer support. You have a 2-year warranty on your device. Warranty repairs are free within this period. Please refer to our FAQ (<https://mntre.com/faq.html>) for more

details.

8.1.2 Serial Console

If you have good Linux knowledge and surmise the boot issue is not hardware related, you can try investigating it using the serial (UART) console.

Since version 3.0, the MNT Reform motherboard has an integrated USB-to-UART chip that makes one of two serial ports of the main processor (and optionally a serial port to the system controller) available on the USB-C power delivery connector. If you connect another computer to this port using a USB-C cable, two virtual serial ports will appear (`tttyACM0` and `tttyACM1` on Linux). You can skip the wiring part in the following section, but the baud rates in the table still apply. Access to the serial ports via USB-C is disabled by default. You can enable them using the DIP switch SW4, located close to the processor module. You might need to remove the heatsink to be able to reach DIP switch SW4. You can enable S1 by setting switch 1 and 2 to the *ON* position. You can then reach S1 using `tttyACM0` on the host computer. You can enable S2 by setting switch 3 and 4 to the *ON* position. To disable access to the serial ports via USB-C, you can turn off all the switches of SW4.

The motherboard connectors labeled S1 and S2 are serial ports (UART) to which U-Boot and the Linux kernel output diagnostic information on startup. The correct serial port depends on your Processor Module:

Module	Port	Baud
i.MX8MQ	S1	115200
i.MX8MPlus	S2	115200
LS1028A	S1	115200
RCM4-BPi/A311D	S2	115200
RCM4-RPi	S1	115200
RK3588	S1	1500000

Wire up a 3.3V USB-to-UART adapter to the following pins of connector J18 (S1) or J20 (S2):

Pin	Function
1	UART1_TXD, connect to RX of your adapter
2	UART1_RXD, connect to TX of your adapter
3	GND, connect to GND of your adapter

Then, use a terminal program such as `tio` on your host computer:

```
tio /dev/ttyUSB0 -b 115200 # Check Module manual
                        # for baud rate
```

If you then switch on Reform (powered by the wall adapter) with the provided SD card inserted, you should see the U-Boot console in `tio`.

8.1.3 Electronics Repair

Before attempting a board-level electronics repair, and especially inside your warranty period of 2 years, please contact our customer support at support@mntre.com. Additionally, please consult the MNT Community forum (<https://community.mnt.re>) for similar issues. Check our repair guides if you are knowledgeable with electronics. Open the respective KiCad file, for example the motherboard file, and take a look at the schematics and PCB layout. You can trace the power rails and measure them at different points on the board. You need a digital multimeter for this.

Either wall or battery power will be regulated to ~29V by the buck-boost regulator/charger LTC4020 and output to the main system regulators. U14 is the always-on 3.3V regulator that powers critical chips like the System Controller (LPC11U24, U18). You can confirm `LPC_VCC` power with 3.3V on J22 pin 15.

Two white indicator LEDs on the motherboard, D11 and D12, signal that 3.3V and 5V rails are turned on, respectively.

Because of the level shifters U28 and U8, booting from SD card requires both 3.3V and 1.8V rails to work. You can measure 1.8V on C130, for example.

The USB hub U9 and the MIPI to eDP converter U10 also need 1.2V power to work (measure on C37). The display itself requires the `3V3_PWR_AUX` (3.3V) and `USB_PWR` (5V) rails to be switched on by the System Controller.

8.1.4 System Controller

The System Controller has to have working firmware to turn on the main power rails. If it is not responding to commands from the OLED menu, the first thing you can do is pressing the `LPC_RST` button on the motherboard to reset the System Controller.

8.1.5 Software Issues

If you suspect software issues, run the `reform-check` command (see “Software” chapter, “Reform Tools” section in this handbook).

8.2 System Boot

Unlike a PC that uses BIOS, Reform utilizes U-Boot, a bootloader commonly used on ARM processors. At the time of writing, Reform only supports ARM based modules.

The Processor Module will usually try to load boot code from its integrated eMMC flash memory, or alternatively, an SD card. Since late 2024, MNT Reform Processor Modules come with U-Boot on eMMC. Refer to the module documentation for further information.

U-Boot is like a mini operating system and shell that allows you to inspect parts of the system (like PCIe, USB devices or Ethernet) and set up parameters to be passed to the real operating system kernel such as Linux, and start it. Every

module has its own U-Boot version, specifically adapted for Reform. The sources and build instructions for all versions can be found at: <https://source.mnt.re/reform>

U-Boot needs 3 files to boot Linux:

- The Linux kernel itself, named `vmlinuz-...-reform2-arm64`.
- The device tree blob (DTB). The file has a Processor Module specific file name ending with `.dtb`. The device tree is a data structure that lists the addresses of and parameters for all the devices in the system that Linux needs to initialize drivers for.
- U-Boot looks for a file called `boot.scr` on the boot medium, which is a script of commands that performs the actual loading of the OS. This script is normally managed by Debian and has a binary header.

Theoretically, you can boot other operating systems and Linux distributions besides Debian, such as FreeBSD, NetBSD, OpenBSD—if they include all necessary drivers for your Processor Module and provide an `extlinux.conf` file for U-Boot. Refer to <https://docs.u-boot.org> for details. Booting another Linux distribution can be achieved by combining the MNT Reform Linux kernel and DTB on the boot partition with the distribution's root file system extracted to the second partition.

Chapter 9

Schematics

All of our Reform-related schematics, design files and documentation are publicly available on our GitLab instance:

<https://source.mnt.re/reform/reform>

All folders that have "pcb" in their name contain KiCad projects that you can explore interactively.

9.1 Motherboard Schematics

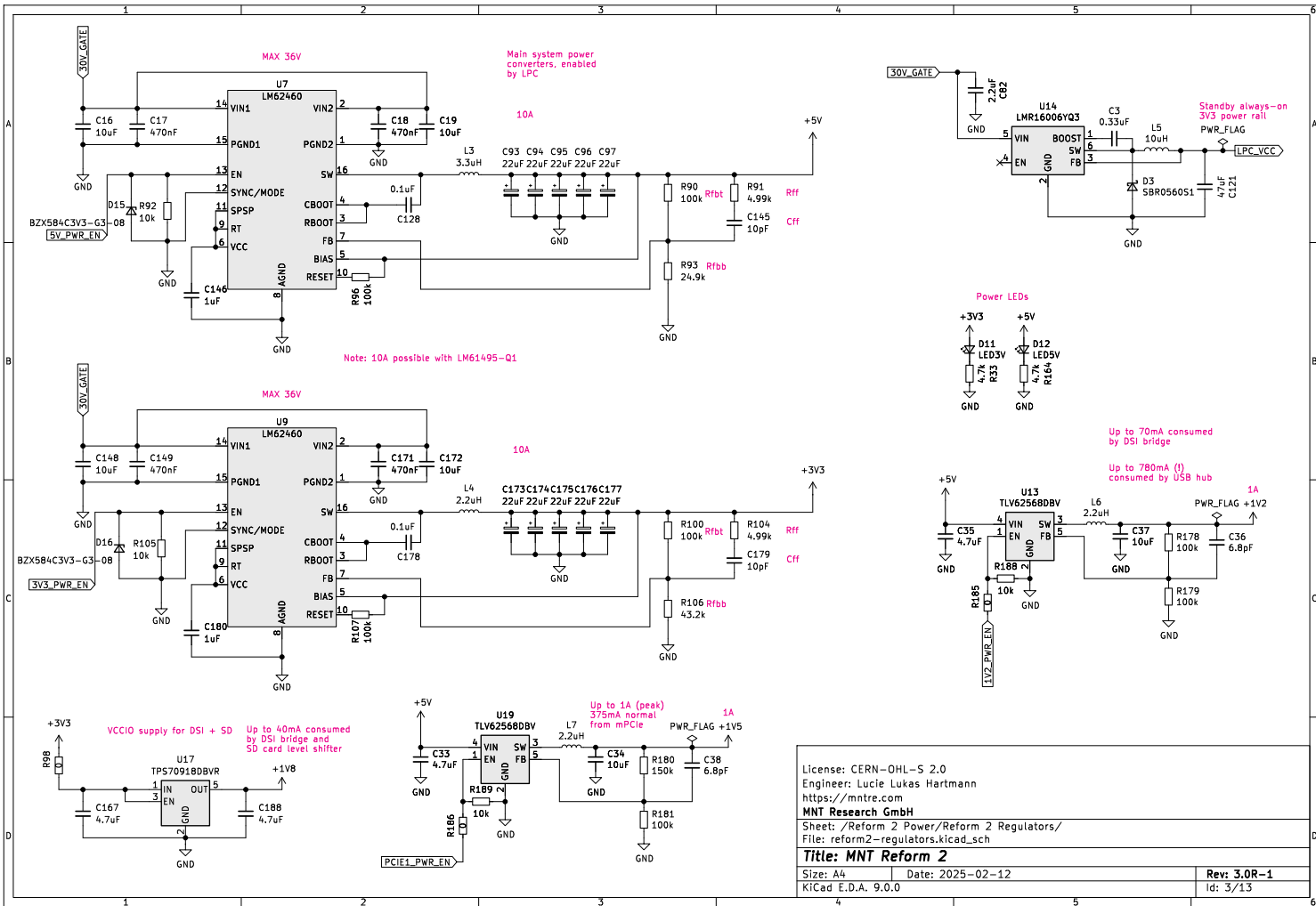

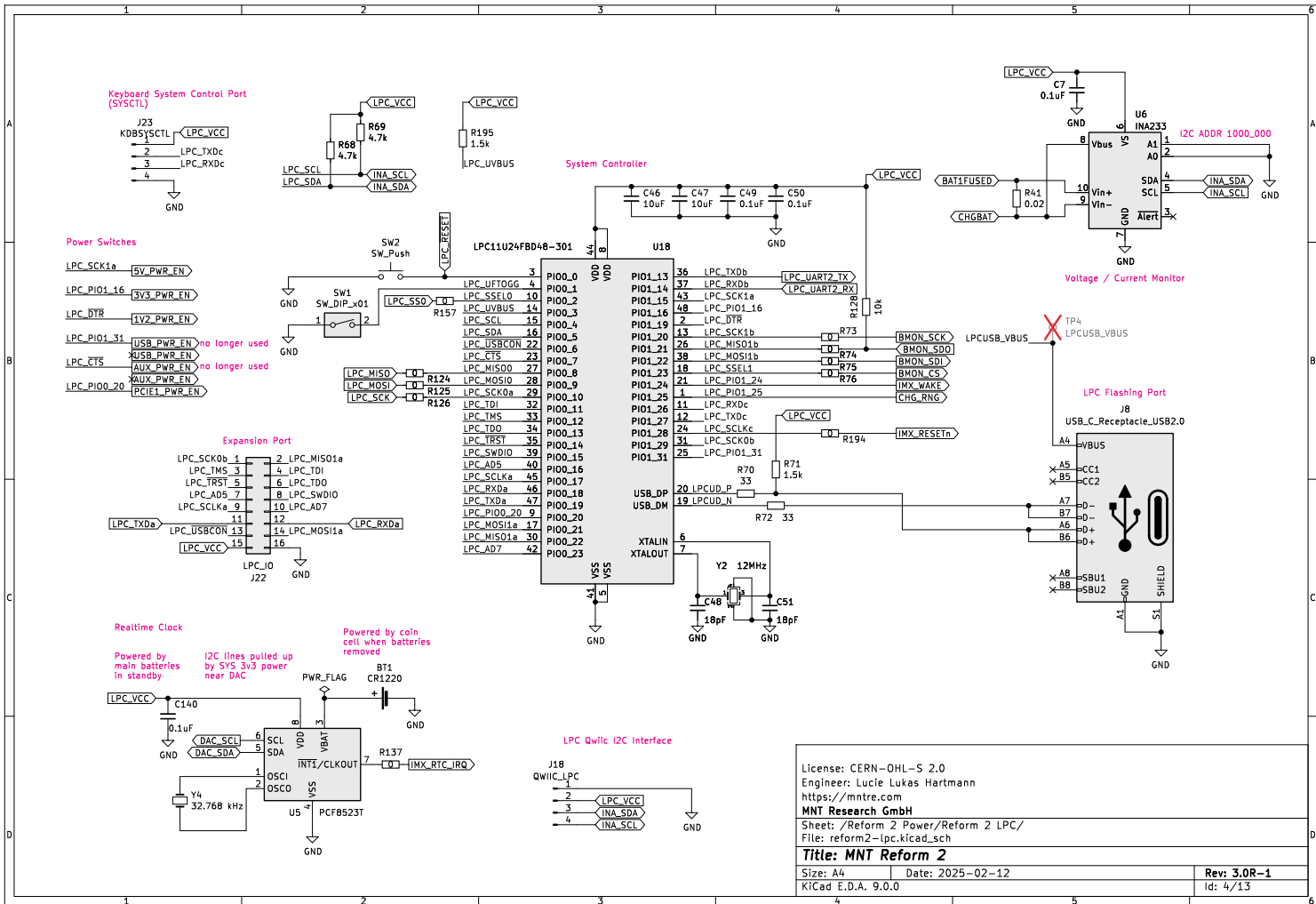

License: CERN-OHL-S 2.0		Engineer: Lucie Lukas Hartmann	
https://mntre.com		MNT Research GmbH	
Sheet: /Reform 2 Power/Reform 2 LPC/		File: reform2-lpc.kicad_sch	
Title: MNT Reform 2			
Size: A4	Date: 2025-02-12	Rev: 3.0R-1	
KiCad E.D.A. 9.0.0		Id: 4/13	

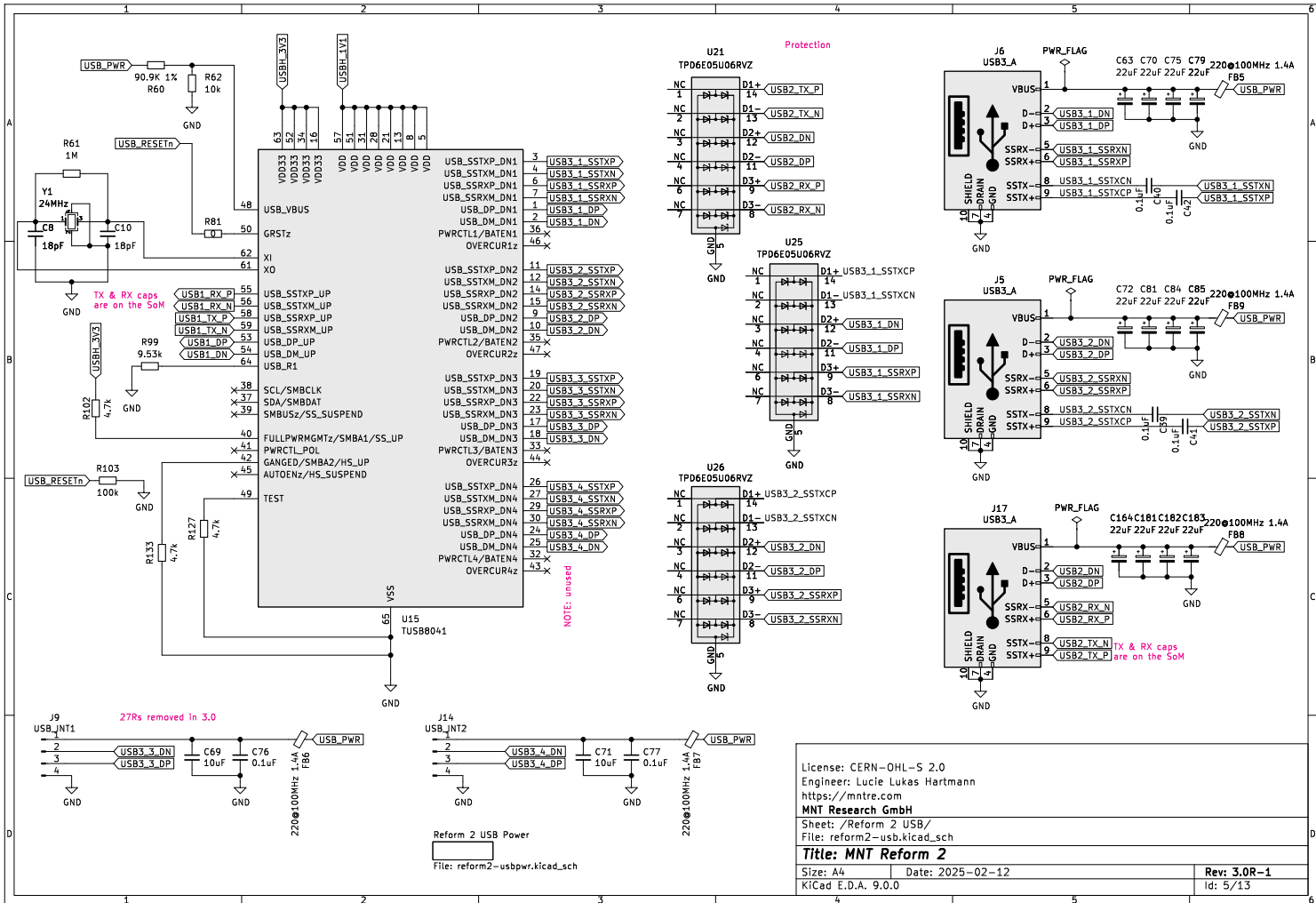

License: CERN-OHL-S 2.0
 Engineer: Lucie Lukas Hartmann
<https://mntre.com>
 MNT Research GmbH
 Sheet: /Reform 2 USB/
 File: reform2-usb.kicad_sch

Title: MNT Reform 2

Size: A4 Date: 2025-02-12
 KiCad E.D.A. 9.0.0

Rev: 3.0R-1
 Id: 5/13

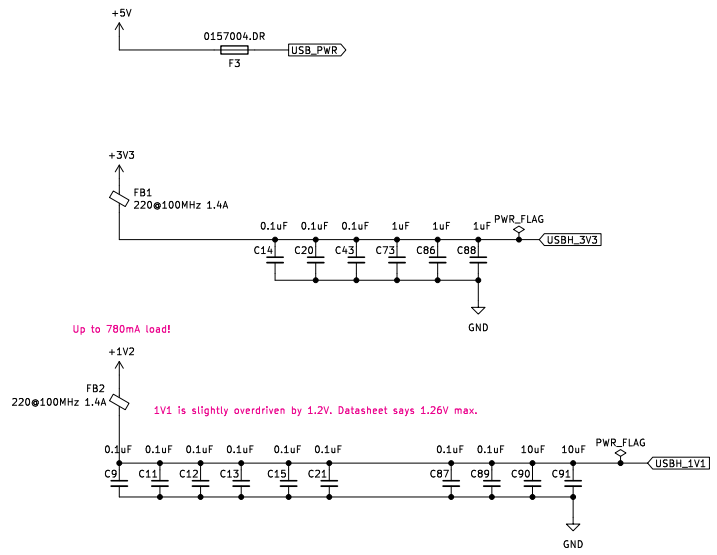

License: CERN-OHL-S 2.0		
Engineer: Lucie Lukas Hartmann		
https://mntre.com		
MNT Research GmbH		
Sheet: /Reform 2 USB/Reform 2 USB Power/		
File: reform2-usbpwr.kicad_sch		
Title: MNT Reform 2		
Size: A4	Date: 2025-02-12	Rev: 3.0R-1
KiCad E.D.A. 9.0.0		Id: 6/13

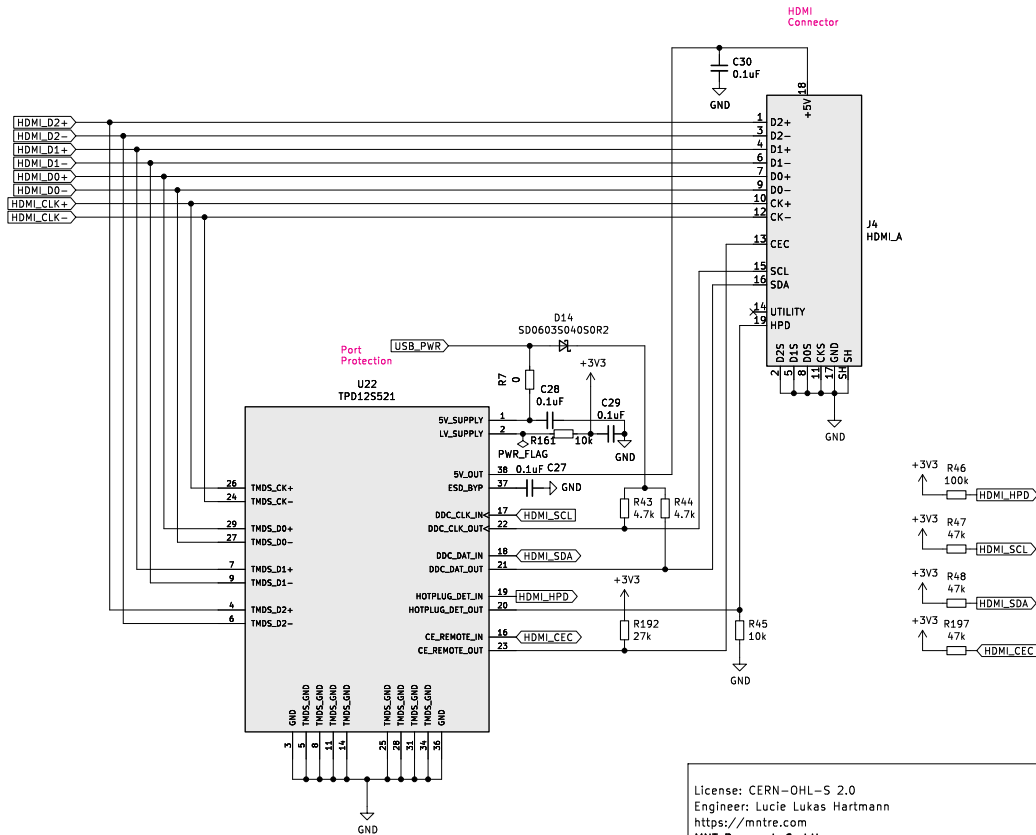

License: CERN-OHL-S 2.0
 Engineer: Lucie Lukas Hartmann
<https://mntre.com>
 MNT Research GmbH
 Sheet: /Reform 2 HDMI/
 File: reform2-hdmi.kicad_sch

Title: MNT Reform 2

Size: A4 Date: 2025-02-12
 KiCad E.D.A. 9.0.0

Rev: 3.0R-1
 Id: 7/13

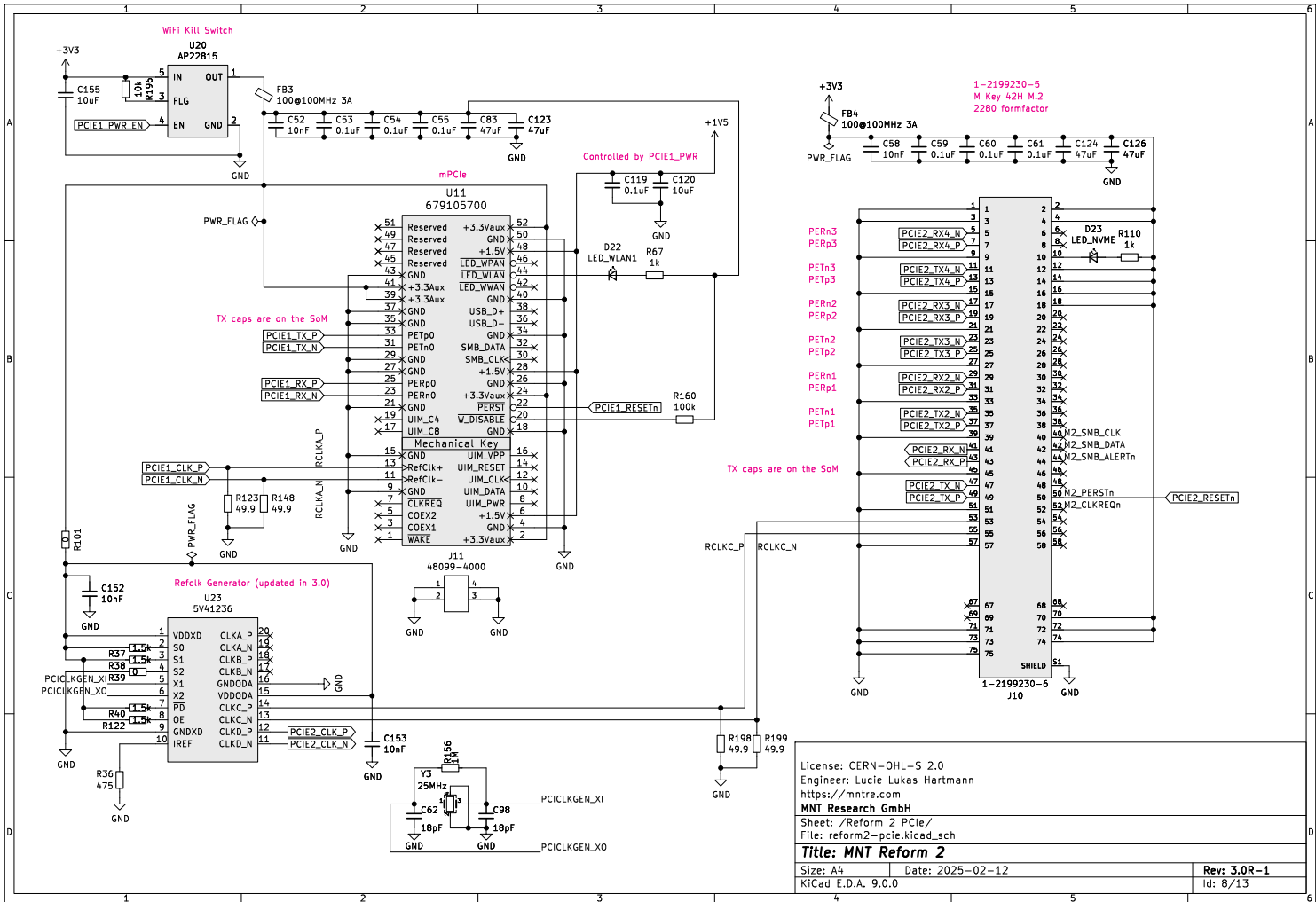

License: CERN-OHL-S 2.0
 Engineer: Lucie Lukas Hartmann
<https://mntre.com>
 MNT Research GmbH
 Sheet: /Reform 2 PCIe/
 File: reform2-pcie.kicad_sch

Title: MNT Reform 2

Size: A4 Date: 2025-02-12

KiCad E.D.A. 9.0.0

Rev: 3.0R-1
 Id: 8/13

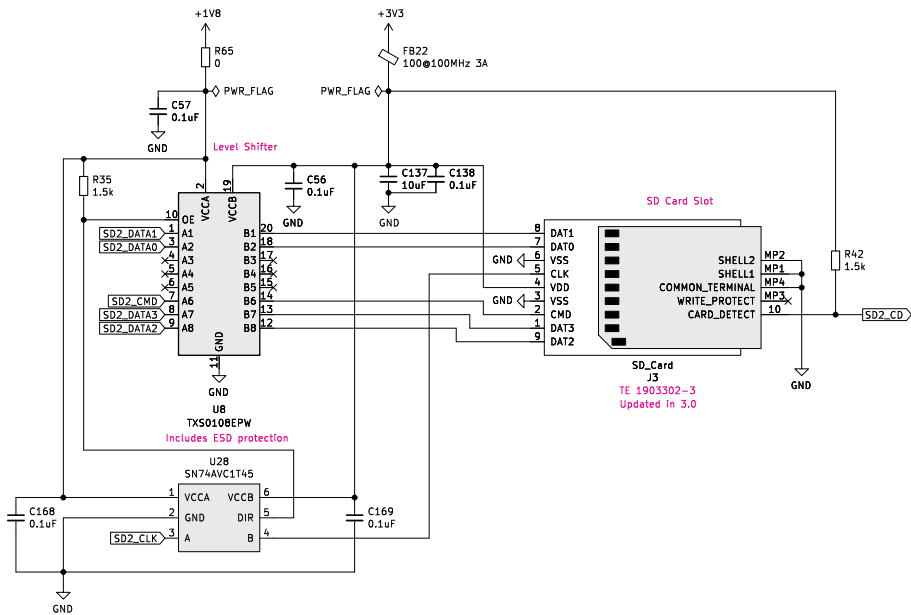

License: CERN-OHL-S 2.0
 Engineer: Lucie Lukas Hartmann
<https://mntre.com>
 MNT Research GmbH
 Sheet: /Reform 2 SD Card/
 File: reform2-sd.kicad_sch

Title: MNT Reform 2

Size: A4 Date: 2025-02-12
 KiCad E.D.A. 9.0.0

Rev: 3.0R-1
 Id: 9/13

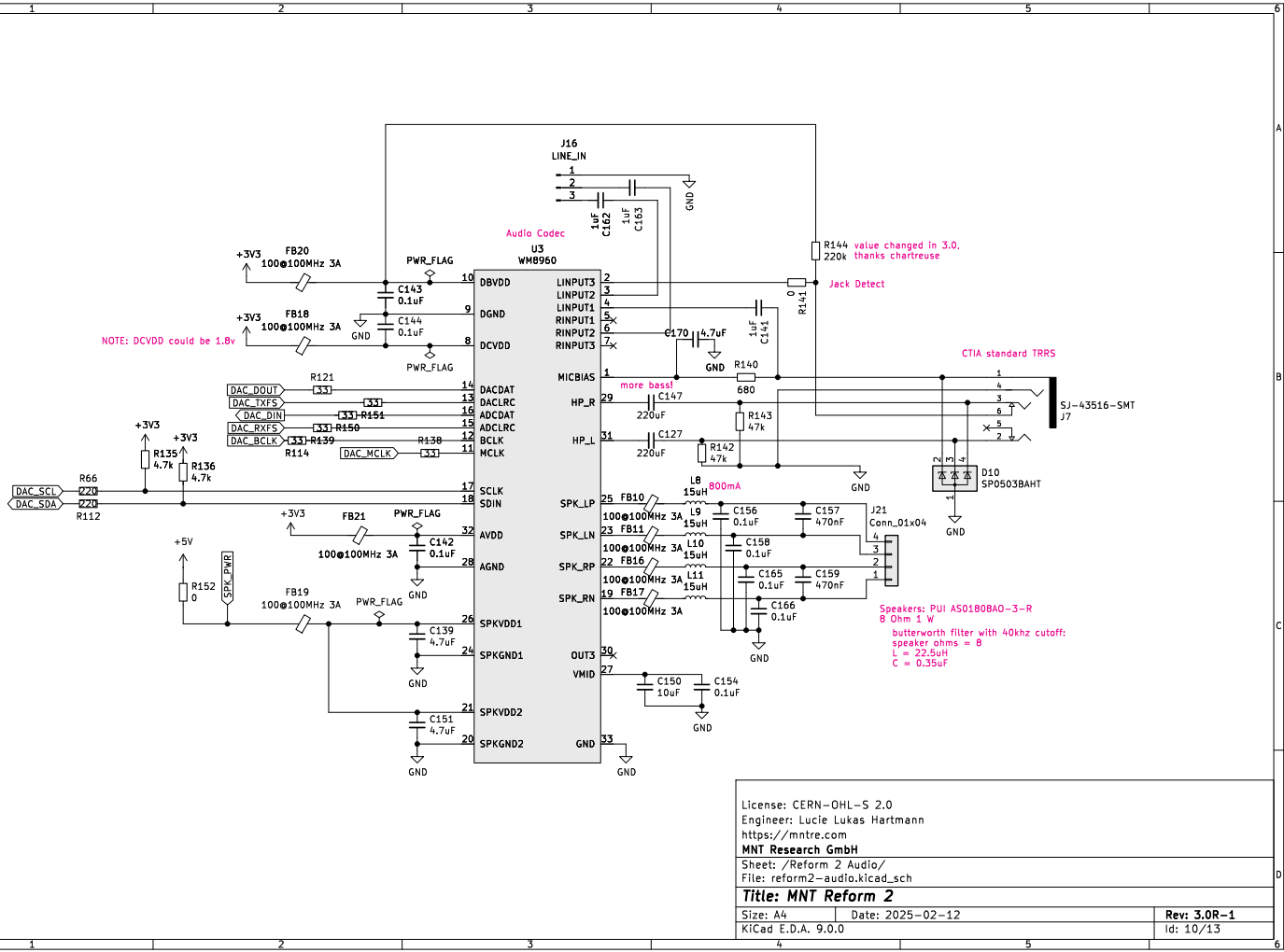

License: CERN-OHL-S 2.0
 Engineer: Lucie Lukas Hartmann
<https://mntre.com>
 MNT Research GmbH
 Sheet: /Reform 2 Audio/
 File: reform2-audio.kicad_sch

Title: MNT Reform 2		
Size: A4	Date: 2025-02-12	Rev: 3.0R-1
KiCad E.D.A. 9.0.0		Id: 10/13

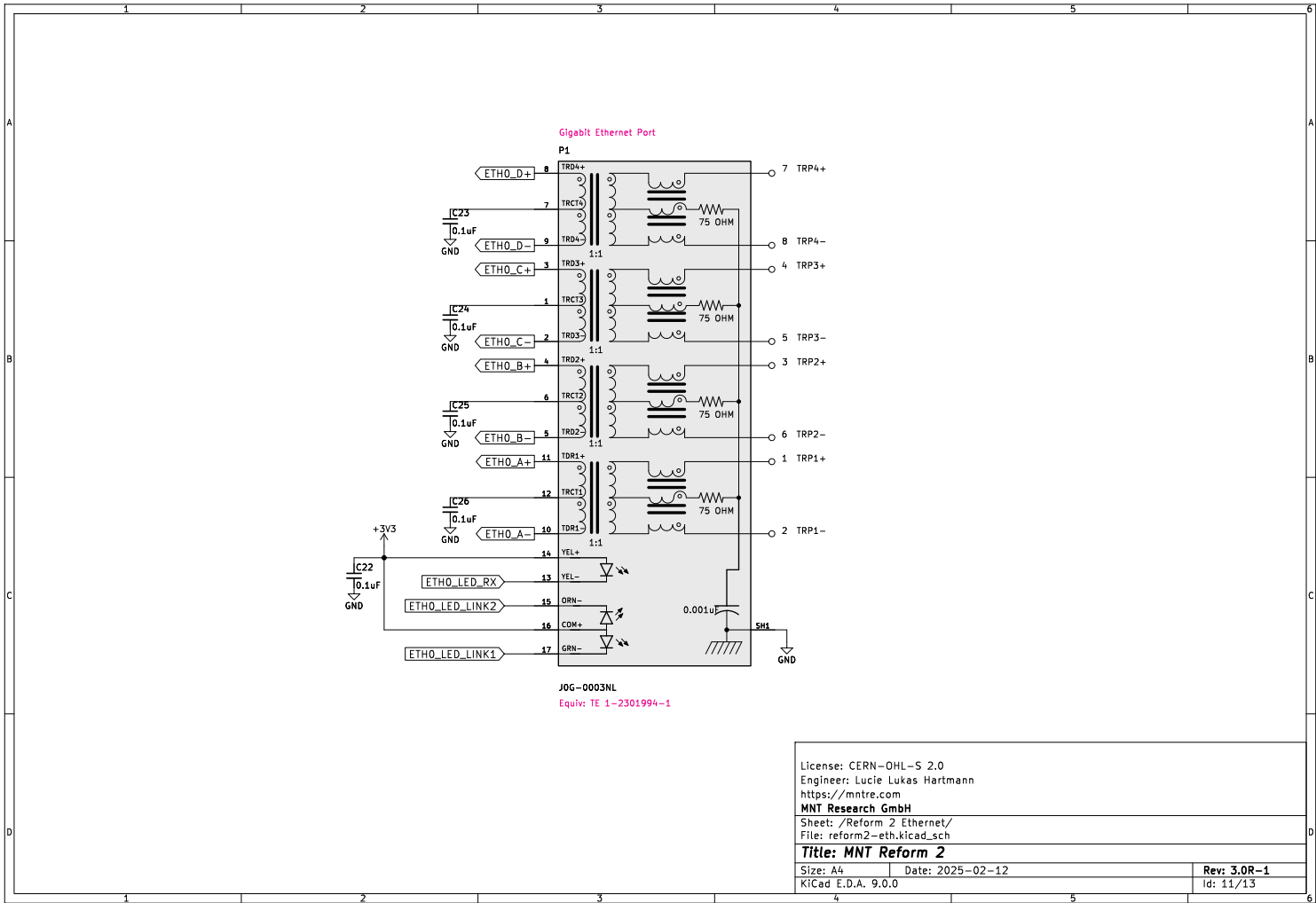

License: CERN-OHL-S 2.0		
Engineer: Lucie Lukas Hartmann		
https://mntre.com		
MNT Research GmbH		
Sheet: /Reform 2 Ethernet/		
File: reform2-eth.kicad_sch		
Title: MNT Reform 2		
Size: A4	Date: 2025-02-12	Rev: 3.0R-1
KiCad E.D.A. 9.0.0		Id: 11/13

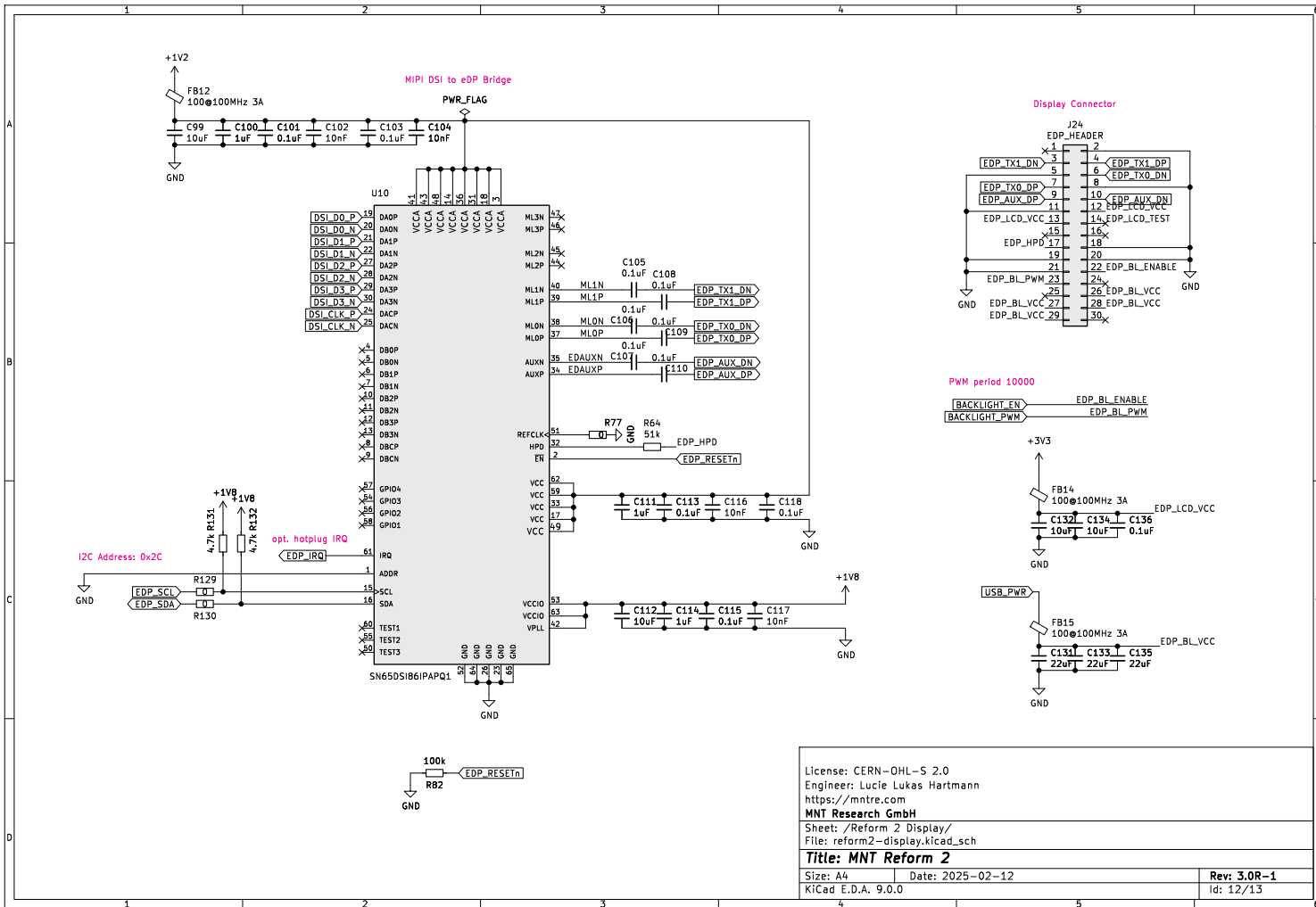

License: CERN-OHL-S 2.0
 Engineer: Lucie Lukas Hartmann
<https://mntre.com>
 MNT Research GmbH
 Sheet: /Reform 2 Display/
 File: reform2-display.kicad_sch

Title: MNT Reform 2

Size: A4 Date: 2025-02-12
 KiCad E.D.A. 9.0.0

Rev: 3.0R-1
 Id: 12/13

9.2 Motherboard Bill of Materials

Designator	Qty	Value	Brand	Part Number
BT1	1		Keystone	3000
C1 C4-C5	14	1uF	Taiyo Yuden	UMK107BJ105KA-T
C32 C73				
C86 C88				
C92 C100				
C111 C114				
C141				
C162-C163				
C2 C7 C9	63	0.1uF	Yageo	CC0603JPX7R9BB104
C11-C15				
C20-C30				
C39-C43				
C49-C50				
C53-C57				
C59-C61				
C76-C77				
C87 C89				
C101 C103				
C105-C110				
C113 C115				
C118-C119				
C136 C138				
C140				
C142-C144				
C154 C156				
C158				
C165-C166				
C168-C169				
C3 C31 C130	3	0.33uF	TDK	C1608X7R1H334K080AC
C6 C33 C35	11	4.7uF	Murata	GRM188R6YA475KE15D
C68 C80				
C139 C151				
C167 C170				
C184 C188				
C8 C10 C48	6	18pF	Yageo	CC0603JRNPO9BN180
C51 C62 C98				
C16 C19	4	10uF	Murata	GRM21BR61H106KE43L
C148 C172				

Designator	Qty	Value	Brand	Part Number
C17-C18	6	470nF	Samsung	CL10A474KB8NNNC
C149 C157				
C159 C171				
C34 C37	19	10uF	Murata	GRM188R61E106KA73D
C46-C47				
C69 C71 C74				
C78				
C90-C91				
C99 C112				
C120 C132				
C134 C137				
C150 C155				
C187				
C36 C38	2	6.8pF	Vishay	VJ0603A6R8DXQCW1BC
C44 C82	5	2.2uF	Taiyo Yuden	UMK107BBJ225KA-T
C125 C129				
C160				
C45	1	33nF	KEMET	C0603C333J4REC7411
C52 C58	10	10nF	KEMET	C0603C103K5RAC3190
C102 C104				
C116-C117				
C152-C153				
C185-C186				
C63 C70	25	22uF	Murata	GRM187R61A226ME15D
C72 C75				
C79 C81				
C84-C85				
C93-C97				
C131 C133				
C135 C164				
C173-C177				
C181-C183				
C64	1	2nF	Murata	GRM1885C1H202JA01D
C65	1	680pF	KEMET	C0603C681J5GACTU
C66-C67	2	330pF	Murata	GCM1885C1H331JA16D
C83 C121	5	47uF	Murata	GRM188R60J476ME15D
C123-C124				
C126				
C122 C161	2	100uF	Panasonic	EEE-FTH101XAP
C127 C147	2	220uF	Murata	GRM32ER60J227ME05L
C128 C178	2	0.1uF	Samsung	CL05B104KO5NNNC

Designator	Qty	Value	Brand	Part Number
C145 C179	2	10pF	Murata	GRM1555C1H100FA01D
C146 C180	2	1uF	Murata	GRM155R6YA105ME11J
D1 D10	2		Littelfuse	SP0503BAHTG
D2 D29-D30	3		Nexperia	BAT46WJ,115
D3-D6	4		Diodes, Inc.	SBR0560S1-7
D7	1		Diodes, Inc.	BZT52C6V2-7-F
D8	1		Vishay	VLMS1300-GS08
D9	1		Vishay	VLMS1300-GS08
D11	1		Vishay	VLMS1300-GS08
D12	1		Vishay	VLMS1300-GS08
D13	1		Vishay	P4SMA24CA-E3/61
D14	1		AVX	SD0603S040SOR2
D15-D16	2		Vishay	BZX584C3V3-G3-08
D17-D19	8		Nexperia	PMEG10020ELR-QX
D24-D28				
D22	1		Vishay	VLMS1300-GS08
D23	1		Vishay	VLMS1300-GS08
F2-F3	2		Littelfuse	0157004.DR
FB1-FB2	7		Murata	BLM18PG221SH1D
FB5-FB9				
FB3-FB4	14		Murata	BLM18KG101TN1D
FB10-FB12				
FB14-FB22				
H1	1		Würth	9774020243R
H2	1		DNP	DNP
H3	1		DNP	DNP
H5-H8	4		DNP	DNP
H9	1		DNP	DNP
H10	1		DNP	DNP
H11	1		DNP	DNP
H12	1		DNP	DNP
H13	1		DNP	DNP
H14	1		DNP	DNP
H15	1		DNP	DNP
H22	4		Würth	9774025243R
H24-H25				
H27				
J1	1		JST	B2B-PH-K(LF)(SN)(PP)
J2	1		Molex	504050-0591
J3	1		TE	1903302-3
J4	1		Würth	685119134923

Designator	Qty	Value	Brand	Part Number
J5-J6 J17	3		Würth	692121030100
J7	1		CUI	SJ-43516-SMT-TR
J8 J12	2		Korean Hroparts	TYPE-C-31-M-12
J9	1		JST	B4B-PH-K-S(LF)(SN)
J10	1		TE	1-2199230-6
J11	1		Molex	48099-4000
J13	1		Molex	504050-0591
J14	1		JST	B4B-PH-K-S(LF)(SN)
J15	1		Hirose	FH12-33S-0.5SH(55)
J16	1		Generic	3P 2mm pitch THT header
J18	1		JST	SM04B-SRSS- TB(LF)(SN)
J19	1		JST	SM04B-SRSS- TB(LF)(SN)
J21	1		JST	B4B-PH-K-S(LF)(SN)
J22	1		Molex	87914-1616
J23	1		JST	B4B-PH-K-S(LF)(SN)
J24	1		Molex	87758-3016
L1	1	22uH 5A	Würth	7447709220
L2	1		Vishay Dale	IMC1210ER100K
L3	1	3.3uH	Pulse	PA5005.332NLT
L4	1	2.2uH	Bourns	SRP6030CA-2R2M
L5 L12	2	10uH	Taiyo Yuden	CBC3225T100MRV
L6-L7	2	2.2uH	Taiyo Yuden	BRL3225T2R2M
L8-L11	4	15uH	Murata	LQH32PB150MN0L
P1	1		Pulse	J0G-0003NL
Q1-Q2 Q15	4		Vishay	SI7850DP-T1-E3
Q17			Siliconix	
Q4	1		Nexperia	PMV50ENEAR
Q5-Q12	8		Nexperia	PMV50EPEAR
Q18	1		Vishay Siliconix	SI7461DP-T1-E3

Designator	Qty	Value	Brand	Part Number
R2 R7 R39 R51-R52 R57 R65 R73-R78 R81 R83 R85 R98 R101 R111 R120 R124-R126 R129-R130 R137 R141 R152 R154-R155 R157 R182 R185-R186 R193-R194	36	0 Ω	Vishay Dale	CRCW06030000Z0EAC
R3 R46 R56 R82 R86 R103 R160 R178-R179 R181	10	100k Ω	Vishay Dale	CRCW0603100KJNEAC
R4-R6 R61 R156	5	1M Ω	Yageo	RC0603FR-071ML
R8	1	7.15k Ω	Yageo	RC0603FR-077K15L
R9 R45 R54-R55 R59 R62-R63 R84 R95 R113 R115 R128 R161 R172 R188-R189 R196	17	10k Ω	Yageo	RC0603FR-0710KL
R10-R16 R175-R176	9	100 Ω	Vishay Dale	CRCW0603100RFKEAC
R17-R24	8	3.3k Ω	Vishay Dale	CRCW06033K30FKEAC
R25-R32	8	15 Ω	TE Connectivity	CRGCQ2512J15R

Designator	Qty	Value	Brand	Part Number
R33	14	4.7k Ω	Yageo	RC0603FR-074K7L
R43-R44				
R68-R69				
R102 R127				
R131-R133				
R135-R136				
R164 R174				
R34 R180	2	150k Ω	Vishay Dale	CRCW0603150KFKEAC
R35	8	1.5k Ω	Yageo	RC0603FR-071K5L
R37-R38				
R40 R42 R71				
R122 R195				
R36	1	475 Ω	Yageo	RC0603FR-07475RL
R41 R177	2	0.02 Ω	ROHM	LTR18EZPF SR020
R47-R48	6	47k Ω	Vishay Dale	CRCW060347K0FKEAC
R80				
R142-R143				
R197				
R49-R50	2	0.01 Ω	ROHM	LTR18EZPFU10L0
R60	1	90.9k Ω	Vishay Dale	CRCW060390K9FKEA
		1%		
R64	1	51k Ω	Yageo	RC0603FR-0751KL
R66 R112	2	220 Ω	Yageo	RC0603FR-07220RL
R67 R110	4	1k Ω	Yageo	RC0603FR-071KL
R183-R184				
R70 R72	8	33 Ω	Vishay Dale	CRCW060333R0FKEAC
R114 R121				
R138-R139				
R150-R151				
R79	1	100k Ω	DNP	DNP
		NTC		
R87	1	198k Ω	Yageo	RT0603BRD07198KL
R90 R96	4	100k Ω	Yageo	RC0402FR-07100KL
R100 R107				
R91 R104	2	4.99k Ω	Yageo	RC0402FR-074K99L
R92 R105	2	10k Ω	Yageo	RC0402JR-0710K
R93	1	24.9k Ω	Yageo	RC0402FR-0724K9L
R94	1		DNP	DNP
R97	1	2.26k Ω	Yageo	RT0603BRD072K26L
R99 R119	2	9.53k Ω	Vishay Dale	CRCW06039K53FKEAC
R106	1	43.2k Ω	Yageo	RC0402FR-0743K2L

Designator	Qty	Value	Brand	Part Number
R108	1	9.31k Ω	Vishay Dale	CRCW06039K31FKTA
R109 R118	2	191k Ω	Vishay Dale	CRCW0603191KFKEAC
R116	1	162k Ω	Vishay Dale	CRCW0603162KFKEA
R117	1	38.3k Ω	Vishay Dale	CRCW060338K3FKEAC
R123 R148	4	49.9 Ω	Yageo	RC0603FR-1049R9L
R198-R199				
R140	1	680 Ω	Yageo	RC0603FR-07680RL
R144	1	220k Ω	Vishay Dale	CRCW0603220KFKEAC
R145-R146	3	49.9k Ω	Vishay Dale	CRCW060349K9FKEAC
R173				
R192	1	27k Ω	Bourns	CR0603-FX-2702ELF
SW1 SW3	2		Apem	DM01
SW2 SW6	2		USAKRO	UK-B0206-G3.8-250-JZ
SW4	1		Nidec	CHS-06TB1
U1	1		TE	1717254-1
U2	1		Analog Devices	LTC4020EUHF#PBF
U3	1		Cirrus Logic	WM8960CGEFL/V
U4	1		Analog Devices	LTC6803IG-4#PBF
U5	1		NXP	PCF8523T/1,118
U6	1		Texas Instruments	INA233AIDGSR
U7 U9	2		Texas Instruments	LM62460QRPHRQ1
U8	1		Texas Instruments	TXS0108EPW
U10	1		Texas Instruments	SN65DSI86IPAPQ1
U11	1		Molex	67910-5700
U12 U14	2		Texas Instruments	LMR16006YQ3
U13 U19	2		Texas Instruments	TLV62568DBVR
U15	1		Texas Instruments	TUSB8041RGCR
U16	1		Infineon	CY7C65215-32LTXI
U17	1		Texas Instruments	TPS70918DBVR
U18	1		NXP	LPC11U24FBD48-301
U20	1		Diodes, Inc.	AP22815AWT-7

Designator	Qty	Value	Brand	Part Number
U21	3		Texas Instruments	TPD6E05U06RVZ
U25-U26				
U22	1		Texas Instruments	TPD12S521
U23	1		Renesas	5V41236PGGI8
U24	1		Texas Instruments	TPS25730DREFR
U28	1		Texas Instruments	SN74AVC1T45DBVR
Y1	1	24MHz	Seiko Epson	X1E0000210264
Y2	1	12MHz	Seiko Epson	Q22FA23V00418
Y3	1	25MHz	Seiko Epson	X1E0000210648
Y4	1	32.768 kHz	Seiko Epson	Q13FC13500002

9.3 Keyboard Schematics

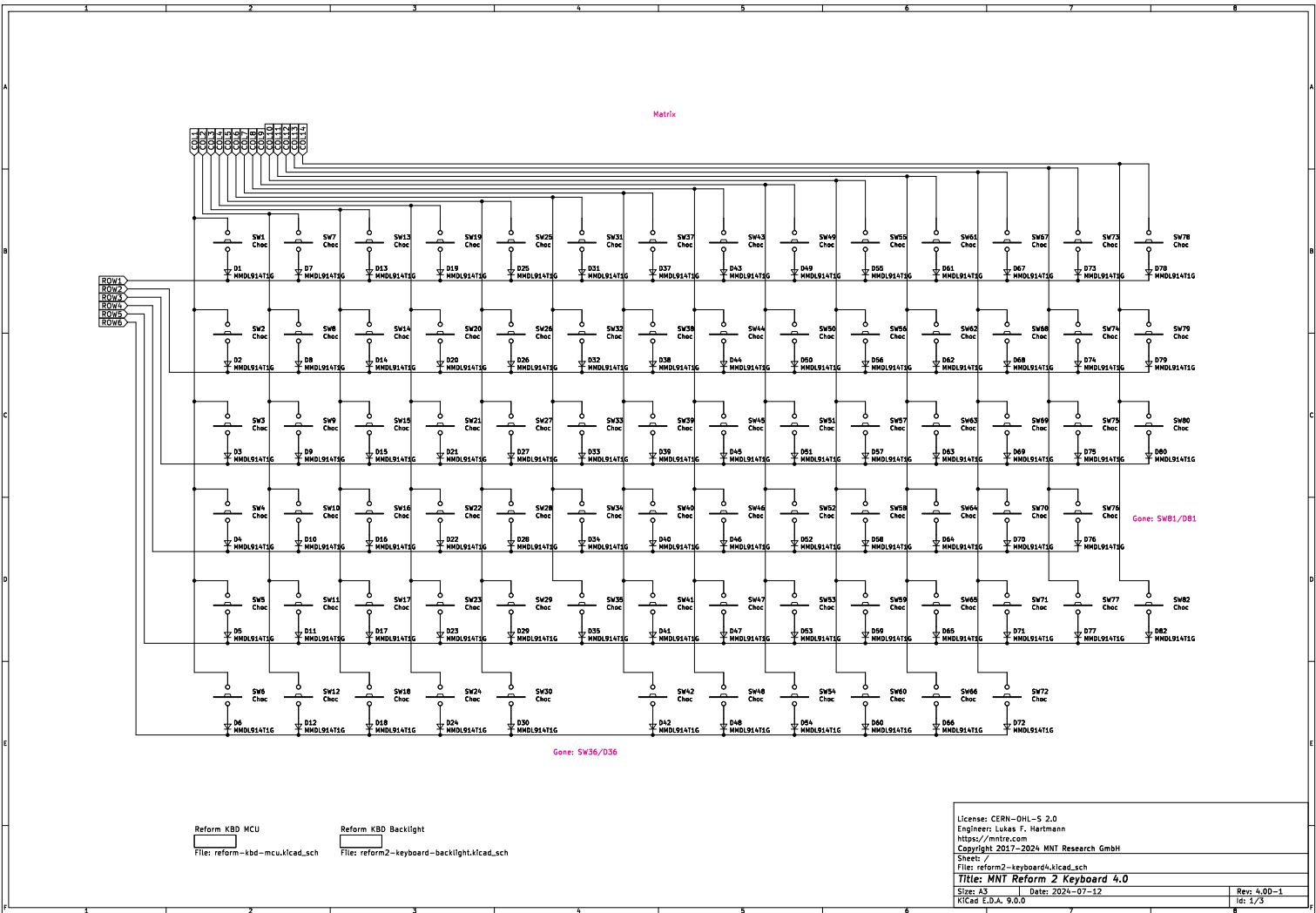

Matrix

Gone: SW81/D81

Gone: SW36/D36

Reform KBD MCU
File: reform-kbd-mcu.kicad_sch

Reform KBD Backlight
File: reform2-keyboard-backlight.kicad_sch

License: CERN-OHL-S 2.0
 Engineer: Lukas F. Hartmann
<https://mntre.com>
 Copyright 2017–2024 MNT Research GmbH
 Sheet: /
 File: reform2-keyboard4.kicad_sch
Title: MNT Reform 2 Keyboard 4.0
 Size: A3 | Date: 2024-07-12 | Rev: 4.0D-1
 KiCad E.D.A. 9.0.0 | Id: 1/3

All LEDs:

56800-EC15

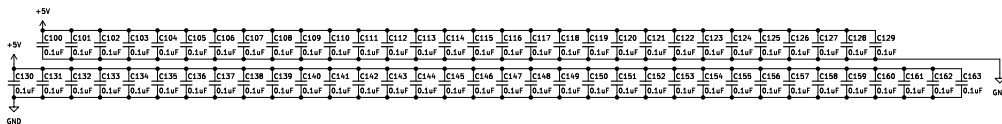
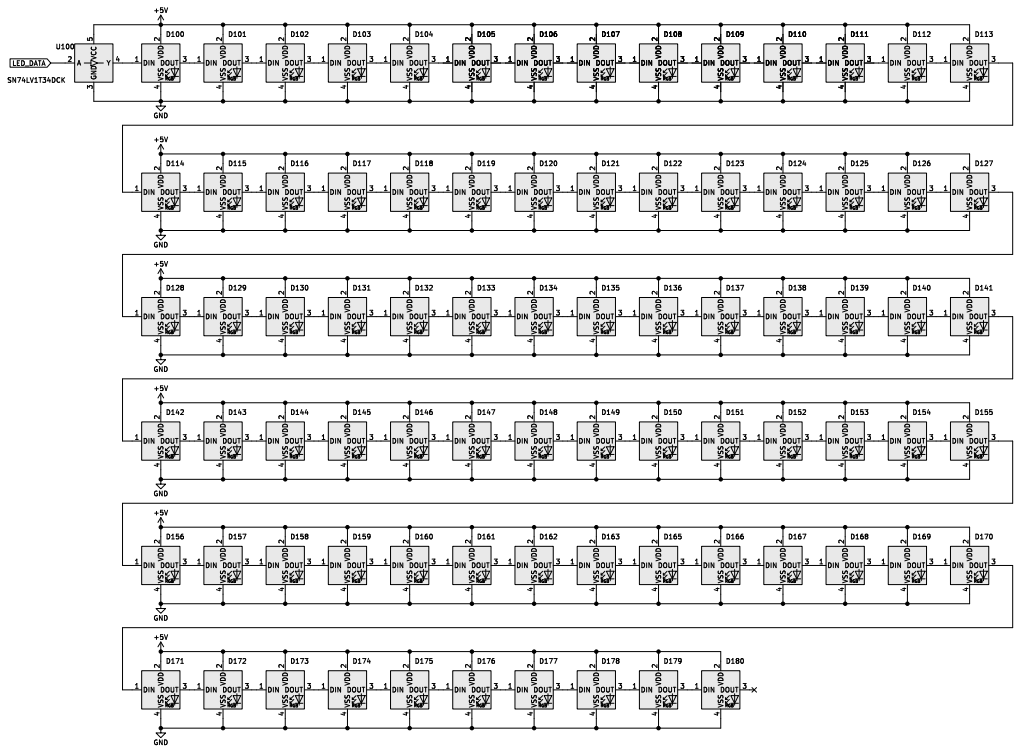

License: CERN-OHL-S 2.0
 Engineer: Lukas F. Hartmann
<https://mnte.com>
 Copyright 2017-2024 MNT Research GmbH
 Sheet: /Reform KBD Backlight/
 File: reform2-keyboard-backlight.kicad_sch
Title: MNT Reform 2 Keyboard 4.0
 Size: A3 | Date: 2024-07-12 | Rev: 4.00-1
 KiCad E.D.A. 9.0.0 | Id: 3/3

9.4 Keyboard Bill of Materials

Designator	Qty	Value	Brand	Part Number
C11-C12 C26	3	1uF	Yageo	CC0603KRX5R8BB105
C14 C16	2	27pF	Yageo	CC0402JRNPO9BN270
C15 C17-C25 C27	11	0.1uF	Samsung	CL05B104KO5NNNC
C100-C179	80	0.1uF	Yageo	CC0603JPX7R9BB104
D1-D35 D37-D80 D82	80		MDD	1N4007WS
D100-D163 D165-D180 D164	80		OPSCO	SK6805-EC15
F1	1		MDD	BZT52C5V6
FB1	1		TECHFUSE	nSMD100-16V
H1-H10	10		Murata	BLM18PG121SN1D
J1	1		DNP	DNP
J2	1		JST	S4B-PH-SM4-K- TB(LF)(SN)
J3	1		JST	SM04B-SRSS- TB(LF)(SN)
J4	1		XFCN	F1002-B-04-20T-R
J5 J100	2		Korean Hroparts	TYPE-C-31-M-12
R13-R14	2	5.1k Ω	Hirose	FH12-6S-0.5SH(55)
R15 R22	2	1k Ω	Yageo	RC0402FR-075K1L
R20	1	10k Ω	Yageo	RC0402FR-071KL
R23-R24	2	27.4 Ω	Yageo	RC0402FR-072R4L
R26-R27	2	4.7k Ω	Yageo	RC0402FR-074K7L
SW1-SW35 SW37-SW80 SW82	80		Kailh	CPG135001D02
SW36 SW84	2		Dongguan Guangzhu	DSIC01LSGET
SW81	1		XKB	TS-1185EC-C-D-B
U3	1		Microchip	MCP1700T-3302E/TT
U4	1		UMW	USBLC6-2SC6
U5	1		Winbond	W25Q32JVSS
U6	1		Raspberry Pi	RP2040

Designator	Qty	Value	Brand	Part Number
U100	1		Texas Instruments	SN74LV1T34DCKR
Y2	1	12MHz 18pF	Seiko Epson	Q22FA23V0041800

9.5 OLED Schematics

SSD1306 OLED
Circuit based on Adafruit 931

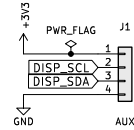
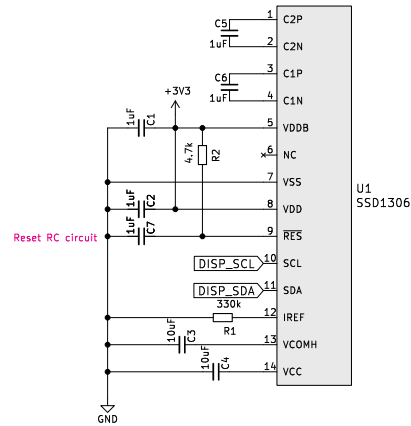

● GFX1
MNT

● GFX2
BADGE

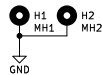

License: CERN-OHL-S 2.0
Engineer: Lukas F. Hartmann
<https://mntre.com>
MNT Research GmbH

Sheet: 7
File: reform2-oled.kicad_sch

Title: MNT Reform 2 Keyboard OLED

Size: A4 Date: 2020-09-08
KiCad E.D.A. kicad 7.0.6+dfsg-1

Rev: 2.0R-1
Id: 1/1

Designator	Qty	Value	Brand	Part Number
C1-C2 C5-C7	5	1uF	Yageo	CC0603KRX5R8BB105
C3-C4	2	10uF	Taiyo Yuden	LMK107BJ106MALTD
H1	1			DNP
H2	1			DNP
J1	1		XFCN	F1002-B-04-20T-R
R1	1	330k Ω	Yageo	RC0603FR-07330KL
R2	1	4.7k Ω	Yageo	RC0603FR-074K7L
U1	1		Enrich Electronics	ENH-OB00910003

9.6 Trackball Schematics

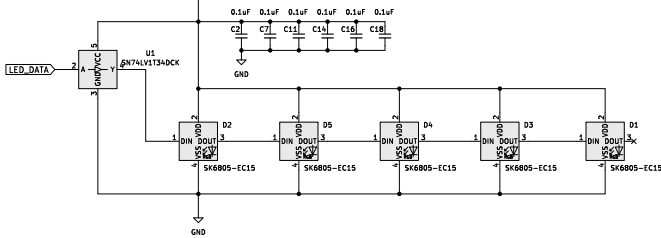
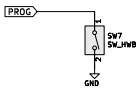
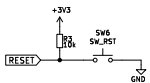
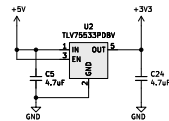
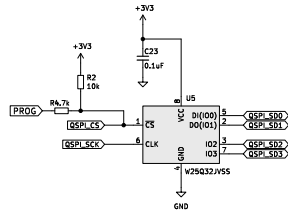
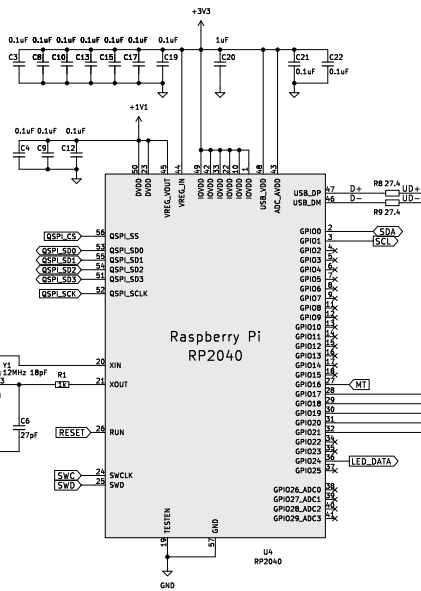
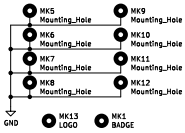
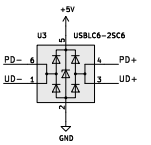
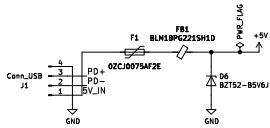

Sensor Connector



Attention! This pinout is mirrored in respect to the trackball sensor for mechanical alignment!

9.7 Trackball Bill of Materials

Designator	Qty	Value	Brand	Part Number
C1 C6	2	27pF	Yageo	CC0603JRNPO9BN270
C2-C4	19	0.1uF	Yageo	CC0603JPX7R9BB104
C7-C19				
C21-C23				
C5 C24	2	4.7uF	Murata	GRM188R61E475KE11D
C20	1	1uF	Yageo	CC0603KRX5R8BB105
D1-D5	5		OPSCO	SK6805-EC15
D6	1		Nexperia	BZT52-B5V6J
F1	1		TECHFUSE	nSMD100-16V
FB1	1		Murata	BLM18PG221SH1D
J1	1		JST	B4B-PH-K-S(LF)(SN)
J2	1		Hirose	FH12-6S-0.5SH(55)
R1	1	1k Ω	Yageo	RC0603FR-071KL
R2-R3	2	10k Ω	Yageo	RC0603JR-0710KL
R4 R10-R11	3	4.7k Ω	Yageo	RC0603FR-074K7L
R8-R9	2	27.4 Ω	Yageo	RC0603FR-0727R4L
SW1-SW5	5		Kailh	CPG135001D03
SW6	1		XKB	TS-1185EC-C-D-B
SW7	1		Dongguan Guangzhu	DSIC01LSGET
U1	1		Texas Instruments	SN74LV1T34DCKR
U2	1		Texas Instruments	TLV75533PDBVR
U3	1		STMicro	USBLC6-2SC6
U4	1		Raspberry Pi	RP2040
U5	1		Winbond	W25Q32JVSS
Y1	1	12MHz 18pF	Seiko Epson	Q22FA23V0041800

9.8 Trackball Sensor Schematics

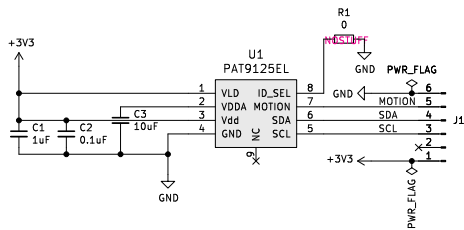

- H1 MountingHole
- H5 MountingHole
- H7 LOGO
- H8 LOGO

License: CERN-OHL-S 2.0
 Engineer: Lukas F. Hartmann
<https://mntre.com>
MNT Research GmbH

Sheet: 7
 File: reform2-trackball-sensor.kicad_sch

Title: MNT Reform Trackball Sensor

Size: A4 Date: 2020-09-08
 KiCad E.D.A. kicad 7.0.6+dfsg-1

Rev: 2.0R-1
 Id: 1/1

9.9 Trackball Sensor Bill of Materials

Designator	Qty	Value	Brand	Part Number
C1	1	1uF	TDK	C1608X8L1C105K080AC
C2	1	0.1uF	Yageo	CC0603JPX7R9BB104
C3	1	10uF	Taiyo Yuden	LMK107BBJ106KALT
J1	1		Hirose	FH12-6S-0.5SH(55)
R1	1	0 Ω	DNP	DNP
U1	1		PixArt Imaging	PAT9125EL

9.10 Trackpad Schematics

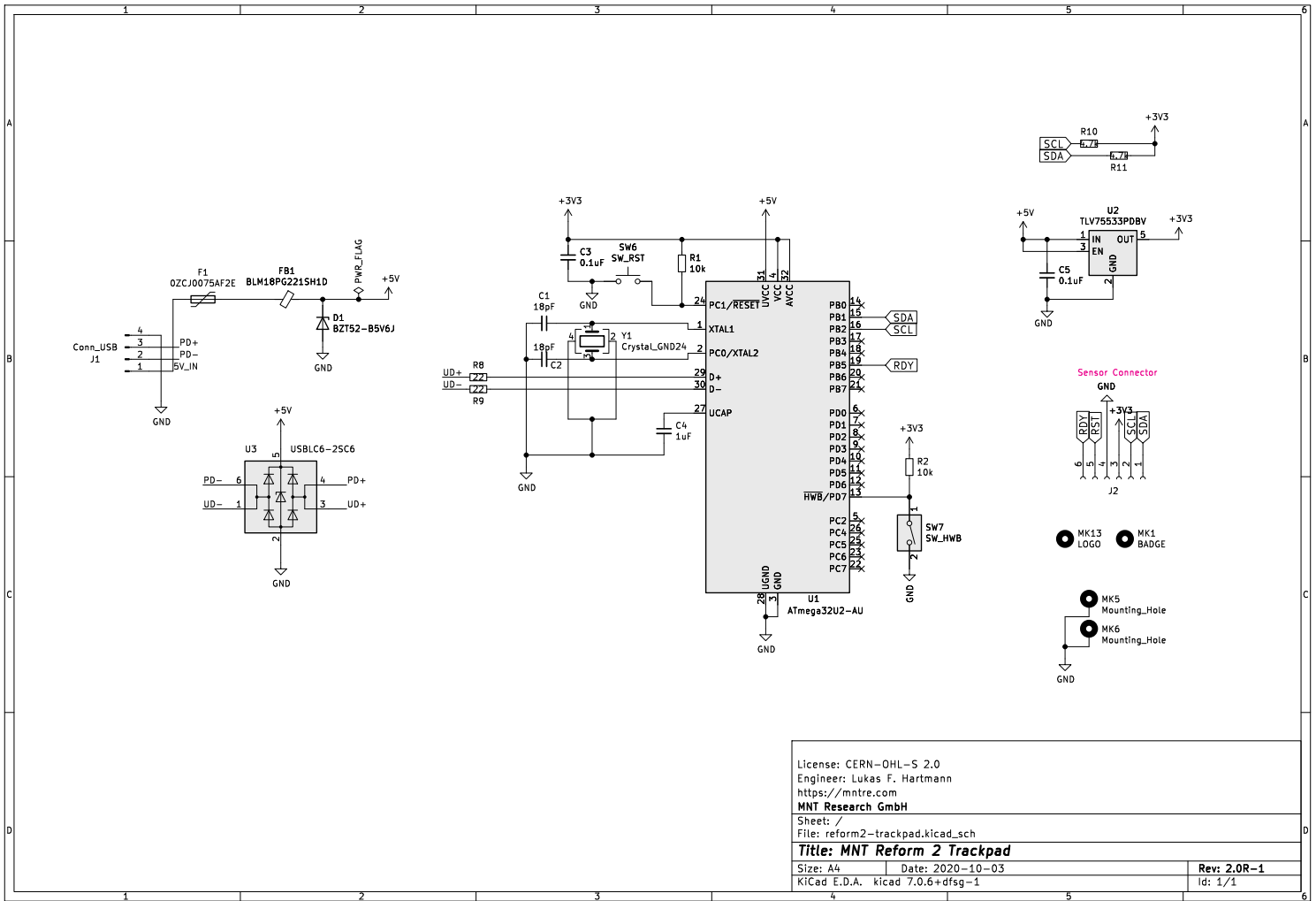

License: CERN-OHL-S 2.0
 Engineer: Lukas F. Hartmann
<https://mntre.com>
MNT Research GmbH

Sheet: 7
 File: reform2-trackpad.kicad_sch

Title: MNT Reform 2 Trackpad

Size: A4 Date: 2020-10-03
 KiCad E.D.A. kicad 7.0.6+dfsg-1

Rev: 2.0R-1
 Id: 1/1

9.11 Trackpad Bill of Materials

Designator	Qty	Value	Brand	Part Number
C1-C2	2	18pF	Yageo	CC0603JRNPO9BN180
C3 C5	2	0.1uF	Yageo	CC0603JPX7R9BB104
C4	1	1uF	Taiyo Yuden	UMK107BJ105KA-T
D1	1		Nexperia	BZT52-B5V6J
F1	1		Bel Fuse	0ZCJ0075AF2E
FB1	1		Murata	BLM18PG221SH1D
J1	1		JST	B4B-PH-K-S(LF)(SN)
J2	1		Hirose	FH12-6S-0.5SH(55)
R1-R2	2	10k Ω	Vishay Dale	CRCW060310K0JNEAC
R8-R9	2	22 Ω	Yageo	RT0603DRD0722RL
R10-R11	2	4.7k Ω	Yageo	RC0603FR-074K7L
SW6	1		Diptronics	PTLP2
SW7	1		Apem	DM01
U1	1		Microchip	ATMEGA32U2-AU
U2	1		Texas Instruments	TLV75533PDBVR
U3	1		STMicro	USBLC6-2SC6
Y1	1	16MHz	Abracon	ABM8AIG-16.000MHz-4-T

9.12 Battery Pack Schematics

Connector pinout is flipped in respect to motherboard pinout

V5 = highest stack voltage

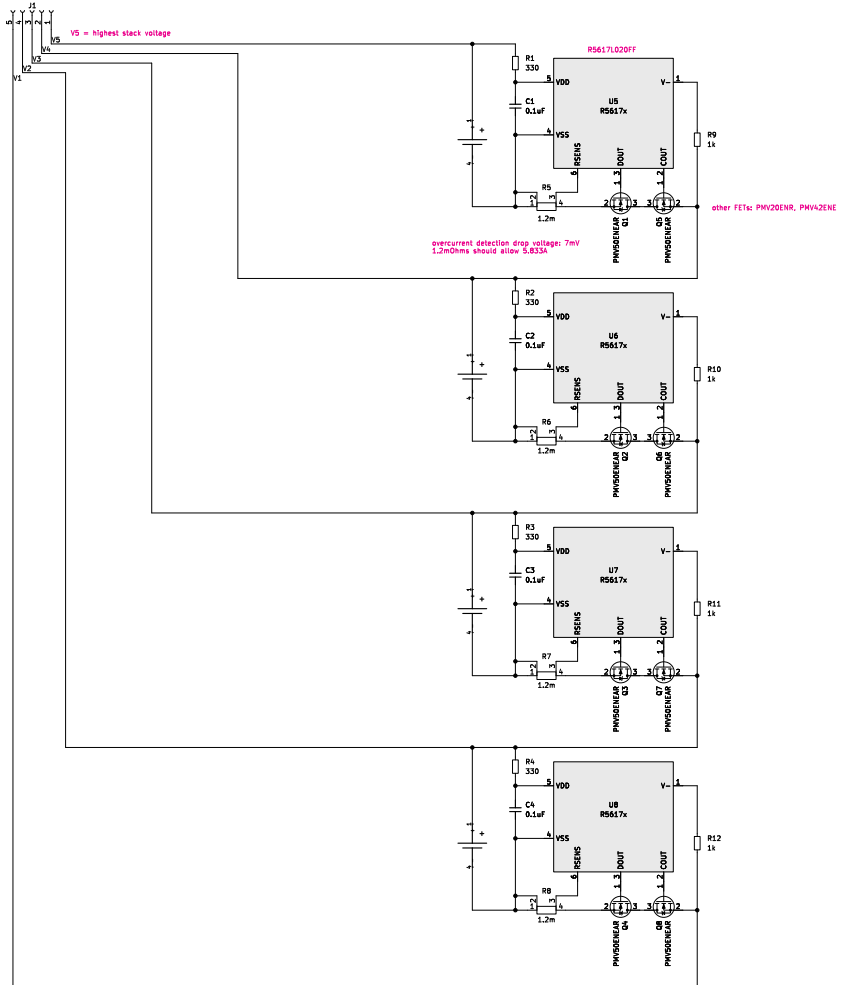

- ⊙ HS MountingHole
- ⊙ H6 MountingHole
- ⊙ H7 MountingHole
- ⊙ H8 MountingHole
- ⊙ H5 Badge

<https://mntre.com>

License: CERN OHL-S 2.0

Engineers: Lukas F. Hartmann

MNT Research GmbH

Sheet: /

File: reform2-protected-batterypack-pcb.kicad_sch

Title: MNT Reform Protected Battery Pack

Size: A3

Date: 2022-10-10

Rev: 2.0 R-2

KiCad E.D.A. kicad 7.0.6+dfsg-1

Id: 1/1

9.13 Battery Pack Bill of Materials

Designator	Qty	Value	Brand	Part Number
C1-C4	4	0.1uF	Generic	0603 0.1uF 50V
J1	1		Molex	504050-0591
Q1-Q8	8		Nexperia	PMV50ENEAR
R1-R4	4	330Ω	Generic	0603 330Ohms
R5-R8	4	1.2mΩ	Generic	1206 1.2mOhms (0.12Ohms) 1%
R9-R12	4	1kΩ	Generic	0603 1kOhms
U1-U4	4		Keystone	54
U5	1		Nisshinbo	R5617L020FF
U6	1		Nisshinbo	R5617L020FF
U7	1		Nisshinbo	R5617L020FF
U8	1		Nisshinbo	R5617L020FF

9.14 Assembly Parts

Part	Qty	Brand	Part Number
USB/SYSCTL Cable JST-PH 4P	3	MNT Research	MREFCBLU20R01
Speaker Cable JST-PH 4P	1	MNT Research	MREFCBLS20R01
eDP I-PEX to DuPont 2mm 2x15P Cable	1	MNT Research	MNT190722001
Sensor Cable 6P 50mm 0.5mm Pitch	1	Würth Elektronik	687606050002
OLED Cable 1mm Pitch 50mm	1	Würth Elektronik	686704050001
MIPI-DSI Cable FPC 0.5mm 33P 50mm	1	Würth Elektronik	687733050002
Battery Cable Picolock	2	Molex	15132-0503
Main Box Al6061 Black	1	MNT Research	MREFCMBT20R01
Bottom Plate Acrylic Transparent	1	MNT Research	MREFCBPL20R01
Keyboard Frame Al6061 Black	1	MNT Research	MREFCKBF20R01

Part	Qty	Brand	Part Number
Left Port Cover Steel Black	1	MNT Research	MREFCPCCL20R01
Right Port Cover Steel Black	1	MNT Research	MREFCPCR20R01
Screen Back Al6061 Black	1	MNT Research	MREFCSCB20R01
Screen Front Al6061 Black	1	MNT Research	MREFCSCF20R01
Right Hinge	1	Smooth Technology	SMS-ZZ-219-L
Left Hinge	1	Smooth Technology	SMS-ZZ-219-R
Neodymium Bar Magnet	8	MNT Research	MREFDMAG20R01
Rubber Foot Transparent	4	Modulor	0303782
Screw M4x5 Countersunk DIN 965H	6	Accu	SIK-M4-5-A2
Screw M2x12 Countersunk DIN 965H	4	Accu	SIP-M2-12-A2
Screw M2x6 Countersunk DIN 965H	18	Accu	SIK-M2-6-A2
Screw M2x4 Pan Head DIN 7985H	30	Accu	SIP-M2-4-A2
Screw M2x5 Black Countersunk DIN 965H	23	Generic	-
Trackball Button Big (SLA)	2	MNT Research	MREFXTB120R02
Trackball Button Small (SLA)	3	MNT Research	MREFXTB220R02
Trackball Cup (PLA)	1	MNT Research	MREFXTBC20R02
Trackball Lid (PLA)	1	MNT Research	MREFXTBL20R02
Trackpad Assembly (PLA/Rubber/Glass)	1	MNT Research	MREFXTPH20R02
Speaker Holder (PLA)	2	MNT Research	MREFXSPK20R02
POM Ball Black 25mm	1	MNT Research	MREFBALB20R02
Trackpad Sensor		Azoteq	TPS65-201A-B
Display Panel eDP IPS 12.5"	1	Innolux	N125HCE-GN1
Speaker	2	PUI Audio	AS01808AO-3-R
Keycap 1U	64	FKcaps	MBK Choc Glow

Part	Qty	Brand	Part Number
Keycap 1U Homing	2	FKcaps	MBK Choc Glow
Keycap 1.25U	4	FKcaps	MBK Choc Glow
Keycap 1.5U	5	FKcaps	MBK Choc Glow
Keycap 1.75U	2	FKcaps	MBK Choc Glow
Keycap 1.5U Convex	2	FKcaps	MBK Choc
Keycap 2U Convex	1	FKcaps	MBK Choc
Power Supply 24V 2.5A 60W	1	Mean Well	GST60A24
Power Cable IEC 60320 C14	1	Depending on Region	-
Battery Cell LiFePO4 18650	1	Eremit	IFR-18650

Chapter 10

Online Resources

Get the latest news and additional resources for MNT Reform at:

- The MNT Research website: <https://mntre.com>
- The MNT Community forum: <https://community.mnt.re>
- Source code repositories (including electronics design files and 3D models for printing and laser cutting): <https://source.mnt.re/reform>
- MNT Research Shop: <https://shop.mntre.com>
- MNT Research Support: <https://support.mnt.re>
- Modularity explained (including a comparison table of Processor Modules): <https://mntre.com/modularity.html>
- PDF and web versions of manuals, including this handbook: <https://mntre.com/docs-reform.html>
- iFixit Maintenance Guides for MNT Reform: https://www.ifixit.com/Device/MNT_Reform
- MNT Research on Crowd Supply: <https://www.crowdsupply.com/mnt>

- MNT Research on the Fediverse: <https://mastodon.social/@mntmn>

You can join fellow MNT Reform enthusiasts in the official IRC channel `#mnt-reform` on `irc.libera.chat`.

Discover more about the main software building blocks of the MNT Reform system:

- Debian GNU/Linux: <https://debian.org>
- U-Boot: <https://docs.u-boot.org/en/latest/>
- Sway: <https://swaywm.org>
- GNOME: <https://gnome.org>

Chapter 11

Credits

The MNT Reform Operator Handbook, Fourth Edition. Berlin, April 2026. Written by Lucie L. Hartmann and Anri Paul Hennies. Published by MNT Research GmbH.

Concept, Electronics, Software Lucie L. Hartmann

Industrial Design Ana Beatriz Albertini Dantas

Quality & Assembly, Sleeve Design Greta Melnik

Handbook Design 100rabbits, Lucie L. Hartmann

Additional Editing Brendan Nystedt, Liaizon Wakest,
Johannes Schauer Marin Rodrigues

3D Illustration Paul Klingberg

Accounting Christian 'plomlompom' Heller

Debian Integration & Tooling Johannes Schauer Marin
Rodrigues

Contributions & Thanks Patrick Wildt, Sigrid Solveig
Hafínudóttir, Cinap Lenrek, Stanley Lieber, Dirk
Eibach, Jacqueline Leykam, Neil Armstrong, John Bliss,
Chartreuse, Norman Feske & Stefan Kalkowski (Genode),
Valtteri Koskivuori, Jack Humbert, Nanocodebug,

Neelfyn, Maximilian Voigt, Helen Leigh, Daniel Amor, Sergio Amor, F. Schneider, Zoé & Elen (Fully Automated), Boundary Devices, Timonsku, L. Stach, Marek Vasut, Christian Gmeiner, Daniel Stone, Simon Ser, Chris Healy, Drew Fustini, Jonas Haring, Philip Steffan, Florian Hadler (Interface Critique), Felix Bayer, LiOn, Schneider, Sven Gebhardt, Jan Varwig, Gabriel Yoran, Martin Meyerhoff, GyrosGeier, Philipp Dikmann, Michael Christophersson, Markus Angermeier

Therapy Dog Tina

Crowdfunding Partner Crowd Supply

Additional Funding NLNet

Printed Circuit Boards PCBWay, JLCPCB

Milling JPR

Inter Font @rsms

Lab Tools Rigol DS1054Z, Fluke 117, Weller WD-1, Puhui T-962C, AmScope SM-4T, BCN3D Sigma R17, Formlabs Form2, Epilog Mini 18, Prusa i3 MK3S+

Software Debian GNU/Linux, KiCad, Inkscape, GIMP, Emacs, Vim, GitLab, LUFA, MicroBuilder, Blender, FreeCAD, OpenSCAD, Fusion, Cura, Sphinx, Pandoc, XeTeX, Scribus

© 2018–2026 MNT Research GmbH, Fehlerstr. 8, 12161 Berlin
 Managing Director: Lucie L. Hartmann
 Registergericht: Amtsgericht Charlottenburg
 Aktenzeichen: HRB 136605 B
 VAT ID: DE278908891
 WEEE: DE 33315564
 Web: <https://mntre.com>

MNT Reform is Open Source Hardware certified by OSHWA (UID DE000017).

The sources for this handbook and most MNT Reform software components (check repositories for details) are

licensed under GNU GPL v3 or newer. The artwork is licensed under CC BY-SA 4.0. The MNT Reform hardware design files are licensed under CERN-OHL-S 2.0. The MNT symbol is a registered trademark of MNT Research GmbH.



PinguinDruck.de

